

FRITZ HANSEN

PROFESSIONALS



THE INVITING WORKSPACE

LET OP: Brochures samengevoegd,
Design collectie vanaf blz 146

Good workspaces are more relevant today than ever before. Moving from the traditional to the inspirational, the inviting workspace is one that encourages communication, collaboration, and creativity.



Oxford™ chair (3243T) in Embrace concrete grey leather.
Pluralis™ table (KS424) in Walnut 82, brushed steel and overhang.

UPLIFTING THE WORKING EXPERIENCE

The way we work is changing. And the demand for a more flexible and inspiring workspace is rising. Reshaping the office as an inviting and creative environment that people want to work in, our products reflect the needs of today to lift the working experience to new heights.

At Fritz Hansen, we believe that a workspace is enhanced by beautiful, functional, and high-quality design.

OXFORD™ & PLURALIS™

Good partnerships come with flexible and focused solutions that set the scene for the modern workspace. The Oxford™ chair and Pluralis™ table unite in beauty and function to optimise the working experience with inviting elegance.

A RELIABLE DESIGN LEGACY

Fritz Hansen has distinguished itself in the world of modern design through an unshakable commitment to beautiful, sophisticated, and functional products that lift the working experience.

As we look toward the future, we strive to continue finding innovative ways to join our expertise in making premium furniture with new technologies and more sustainable materials, so we can continue to offer our customers the very best.

Our legacy is not something we lean back on; it is, rather, what pushes us forward, motivating us to continually do better.





In front **Oxford™** (3191W) in Remix 173 and satin polished aluminium base.
Pluralis™ (KS423) in White 122 laminate and polished aluminium base.

OXFORD™

Arne Jacobsen, 1965

The Oxford™ chair was originally designed in 1965 by Arne Jacobsen for St Catherine's College in England. As a chair for professors in a hallowed institution, it had to be not only comfortable to sit in, but also beautiful to look at.

Reimagined with premium office spaces in mind, the original design is upgraded to modern needs for customisation and comfort. Shaped to support the body as it sits, the classic design is optimised with increased lumbar support.

The Oxford™ chair is a perfect example of how design and function go hand in hand, creating a timeless expression of beauty that enhances your workspace.



The Oxford™ is GREENGUARD Gold Certified.

GREENGUARD Gold Certified products are certified to GREENGUARD standards for low chemical emissions into indoor air during product usage. For more information, visit ul.com/gg.



The mark of
responsible forestry
FSC® C120461

The Oxford™ is FSC™ certified.

FSC certification ensures wood is from forests that are managed with respect for sustainable, social and ethical standards.



Oxford™ chair (3293W) in Walnut Grace leather and Brown bronze base.
Pluralis™ (KS420) in Walnut 82, Veneer and Brown bronze base and Kaiser
Idell (6631-T Luxus) in high gloss and chrome.

STYLE WITH A PURPOSE

OXFORD™

Combining minimalist design with modern technology, the Oxford™ chair is upgraded to ensure supreme sitting comfort.

Offered with a low or tall backrest, increased lumbar support and a longer seat for a more natural sitting posture. Tilt mechanism and adjustable seat height ensure better respond to different body types and activities, while multiple base colour and upholstery textile options allow for total customisation.

Available with a four-star fixed base as well as the classic five-star base with or without casters, that fit any table.

Please find full overview of models at fritzhansen.com. For more information contact your sales representative.



Oxford™ chair (3273W) in Black Grace leather and polished aluminium base.



Model: 3141T
Features: Low back, fixed seat height
Upholstery: Textile Remix 123
Base: Four-star base, Brushed Aluminum



Model: 3171T
Features: Low back, fixed seat height
Upholstery: Textile Remix 173
Base: Five-star base, Warm Graphite



Model: 3271W
Features: Low back, fixed seat height,
armrest, castors
Upholstery: Textile Remix 133
Base: Five-star base, Warm Graphite



Model: 3241T
Features: Low back, fixed seat height,
with armrest
Upholstery: Leather Grace Dark Brown
Base: Four-star base, Brown Bronze



Model: 3191T
Features: Low back, fixed seat height,
height adjustable, tilt
Upholstery: Textile Vidar 222
Base: Five-star base, Brushed Aluminum



Model: 3191W
Features: Low back, fixed seat height,
with castors, height adjustable, tilt
Upholstery: Textile Sonar 0734
Base: Five-star base, Brushed Aluminum



Model: 3143T
Features: Medium back, fixed seat height
Upholstery: Textile Remix 133
Base: Four-star base, Warm Graphite



Model: 3273T
Features: Medium back, fixed seat height,
with armrest
Upholstery: Textile Remix 233
Base: Five-star base, Brushed Aluminum



Model: 3273W
Features: Low back, fixed seat height,
with armrest and castors
Upholstery: Textile Remix 973
Base: Five-star base, Brushed Aluminum 9

ENDLESS POSSIBILITIES & POTENTIAL

As always, our designs can be configured to suit your specific project or need, including material options and technical features.



OXFORD GLIDES

Round glides for five-star base.



Armrests come in leather or hard plastic.

MODEL

The chair comes in low and medium height.

UPHOLSTERY

Choose from a wide range of durable and sophisticated textiles and leathers.

OPTIONS

Tilt mechanism and automatic return.

ARMRESTS

Optional armrests and armpads that fit under the table.

BASES AND COLOURS

Select between four or five star base and choose a colour from the new palette.

CASTORS

Soft or hard castors with or without brakes.

Black or polished aluminium wheel housing.

GLIDES

Select between standard or round glides.



TAILORED TO YOU

A wide range of upholstery, base and colour options unite material with function and cater to specific workspace needs. Made to uplift standards using premium materials that last for generations, our furniture offers supreme durability and a timeless aesthetic. Because we believe that great spaces produce great results.

BASE COLOURS

The base of Oxford™ is available with a four-star fixed base as well as the classic five-star base with or without castors, and comes in the following finishes:

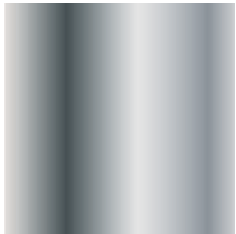

POLISHED ALUMINIUM



SATIN POLISHED
ALUMINIUM

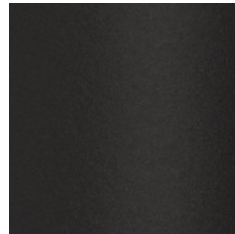

BLACK 190

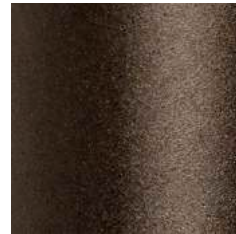

BROWN BRONZE 390
NEW



WARM GRAPHITE 180
NEW

UPHOLSTERY

The Oxford™ chair is available in durable and sophisticated textiles and leathers, as well as bespoke solutions to match your space.

Visit our product configurator at fritzhanzen.com and discover all our standard options.





Oxford™ chair (3191W) in Remix 123 and Warm Graphite. **Pluralis™** table (KS422) in Mauve Brown 361 Linoleum and Warm Graphite base.



FLEXIBLE FUNCTIONALITY

At Fritz Hansen, we believe that elegant design for the modern workplace should support users in the specific ways they need it.

We strive to create office products shaped by innovative functionality and flexibility, from choices of colour, material, and form, to adjustable features that enable multiple levels of customization.



Oxford™ chair (3243T) in Embrace concrete grey leather. **Pluralis™** table (KS424) in Walnut 82, brushed steel and overhang. **Concert™** pendant in white steel.



PLURALIS™

Kasper Salto, 2016/2021

DESIGNED FOR EVERY MEETING

The Pluralis™ table, designed by Kasper Salto, is made with room to grow. Transforming from a solo workstation to a generous conference table, the elegant, modern design is configurable in length and width to serve your workspace needs.

Set on supportive, angled legs retracted from the tabletop to create an inviting look, and additional central leg allows tabletops to be beautifully extended. New base colours offer more ways to customise, while perfectly complementing Fritz Hansen's products to create coherent spaces.

Pre-selected configurations make it easy to structure an office space, and an optional overhang provides additional seating space. Practical power solutions and cable management ensure streamlined simplicity and heightened productivity.



The mark of
responsible forestry
FSC® C120451

The Pluralis™ (KS420-KS425) is FSC™ certified.

FSC certification ensures wood is from forests that are managed with respect for sustainable, social and ethical standards.



Oxford™ chair (3291W) chair in Remix 123 and Vidar 786 and Warm Graphite base. **Pluralis™** table (KS424) in oak veneer, 72 and Warm Graphite base.

DESIGNED FOR EVERY MEETING

As always, our designs can be configured to suit your specific project or need, including material options and technical features.

MODELS

The table comes in different standard widths. An elegant center leg allows tabletops to be extended infinitely.



CABLE MANGEMENT AND POWER SOLUTIONS

Black and silver cable hose for a streamlined look - and multiple power solutions.



OVERHANG

Overhang available at one or both ends (+25 cm / 9.8 in) as a seamless extension of the table.



BASES

Four base colours to complement existing Fritz Hansen products, creating coherent spaces.



TABLETOPS

Choose from five sophisticated tabletops in premium veneer, laminate and linoleum surfaces.



120 cm / 47.2"

AVAILABLE WIDTHS

The table comes in 4 different widths.



Pluralis™ table (KS424) in Walnut 82 veneer and polished aluminium.

TABLETOPS AND BASE COLOURS

TABLETOPS

Pluralis™ is available in a selection of premium materials to match your space and needs.



OAK 72, VENEER



WALNUT 82, VENEER

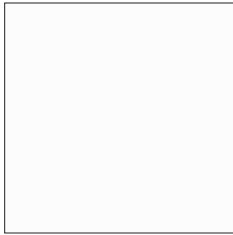

WHITE 122, LAMINATE



LAVA GREY 152,
LAMINATE



MAUVE BROWN 361,
LINOLEUM

BASE COLOURS

The base of Pluralis™ is sculpted from aluminium for lightweight durability. Choose from a selection of premium finishes.

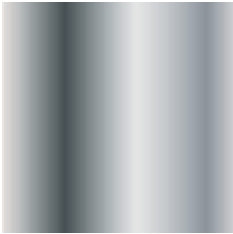

POLISHED ALUMINIUM



BLACK 190



WARM GRAPHITE 180
NEW



BROWN BRONZE 390
NEW

PRE-DESIGNED CONFIGURATIONS

Select pre-designed table configurations in length and width or create your own table. For bespoke solutions or sizes please contact the Fritz Hansen sales team.



Model: KS420

Single tabletop

Available with overhang one- or two end(s) (+25 cm / 9.8")

Minimum weight: 41 kg / 90 lb

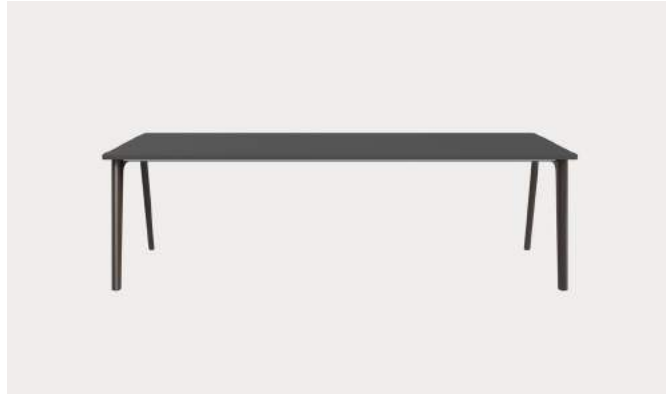

Model: KS421

Single tabletop

Available with overhang one- or two end(s) (+25 cm / 9.8")

Available widths: 80 cm / 31.5", 90 cm / 35.4" or 100 cm / 39.4"

Minimum weight: 46 kg / 101 lb

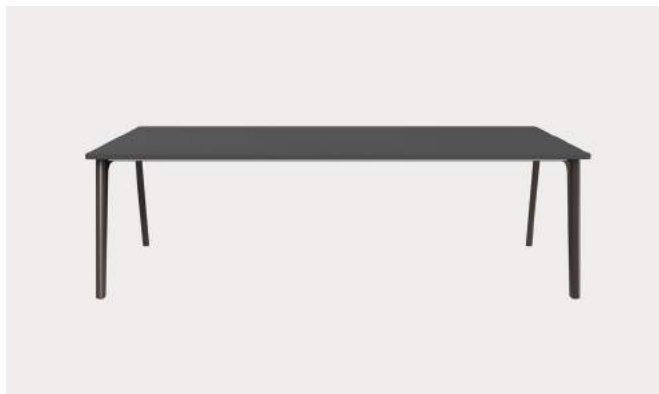

Model: KS422

Single tabletop

Available with overhang one- or two end(s) (+25 cm / 9.8")

Available widths: 80 cm / 31.5", 90 cm / 35.4", 100 cm / 39.4" or 120 cm / 47.2"

Minimum weight: 52 kg / 115 lb

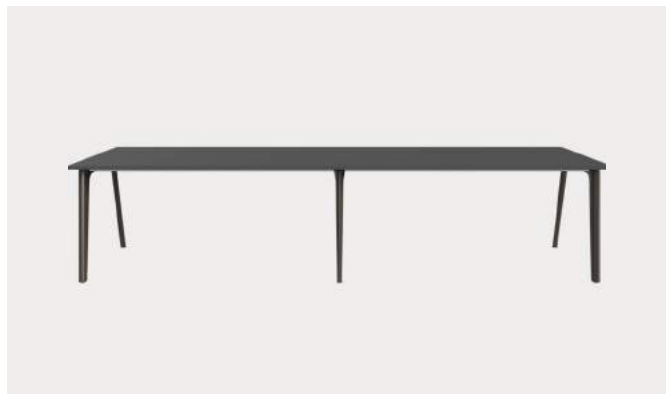

Model: KS423

Two tabletops

Available with overhang one- or two end(s) (+25 cm / 9.8")

Available widths: 80 cm / 31.5", 90 cm / 35.4", 100 cm / 39.4" or 120 cm / 47.2"

Minimum weight: 73 kg / 161 lb

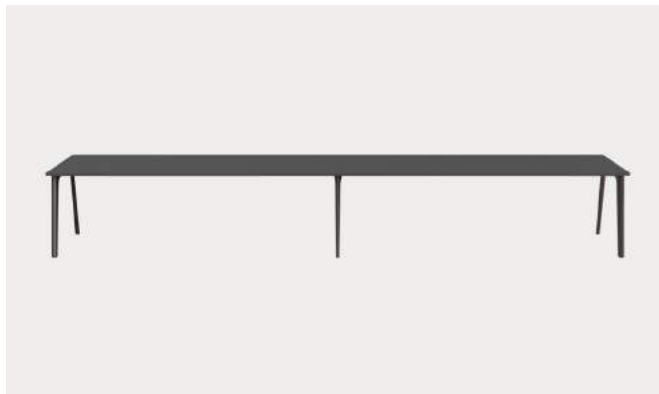

Model: KS424

Two tabletops

Available with overhang one- or two end(s) (+25 cm / 9.8")

Available widths: 80 cm / 31.5", 90 cm / 35.4", 100 cm / 39.4" or 120 cm / 47.2"

Minimum weight: 96 kg / 212 lb

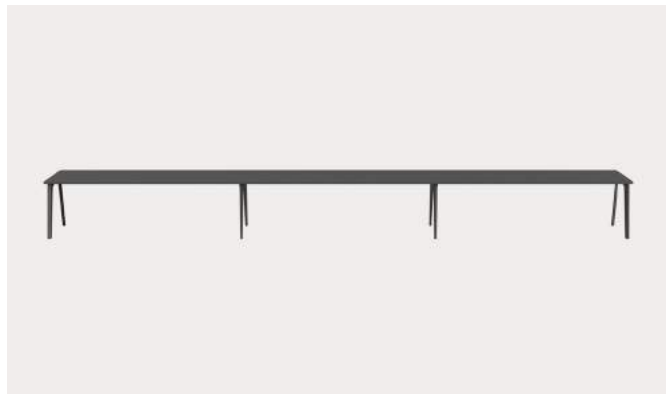

Model: KS425

Three tabletops

Available with overhang one- or two end(s) (+25 cm / 9.8")

Available widths: 80 cm / 31.5", 90 cm / 35.4", 100 cm / 39.4" or 120 cm / 47.2"

Minimum weight: 139 kg / 306 lb



Oxford™ chair (3293W) in Grace Walnut leather.
Pluralis™ table (KS422) Mauve Brown 361 Linoleum
and Warm Graphite base.

EXTRAS AND OPTIONS

Enhance your individual design with optional extras, thoughtfully created to get the best and most out of the selected Oxford™ or Pluralis™.



Power solutions
Power frame in stainless steel or choose a rectangular or round cable well. Bespoke solutions are also available.



Top frame
A top frame with a standard four-socket strip can be integrated into the tabletop and concealed with a discreet lid that opens silently with the touch of a finger. Both lid and frame can be placed in several positions integrated in the tabletop.





Overhang

A seamless extender overhang for both table ends provides additional seating for one and is available to match the tabletop of your choice. A tabletop with overhang comes as a full length tabletop.

DIMENSIONS

OXFORD™

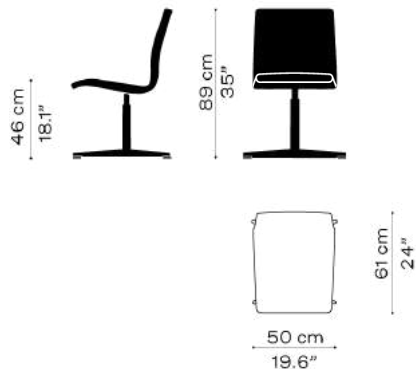

Model: 3141T

Low back
4 Star base
Fixed seat height
Weight: 8,3 kg / 18.3 Lb

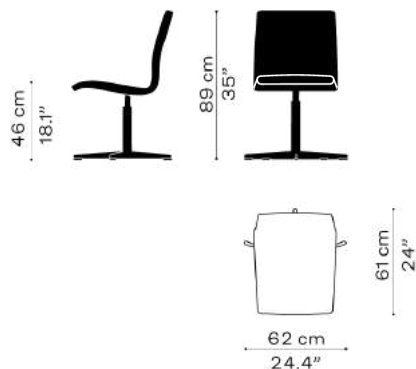

Model: 3171T

Low back
5 Star base
Fixed seat height
Weight: 8,67 kg / 19 lb

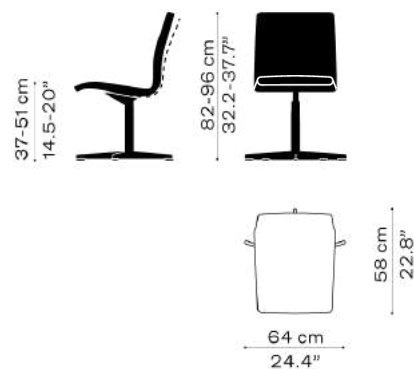

Model: 3191T

Low back
5 Star base
Height adjustable
Tilting mechanism
Weight: 10,8 kg / 23.8 Lb

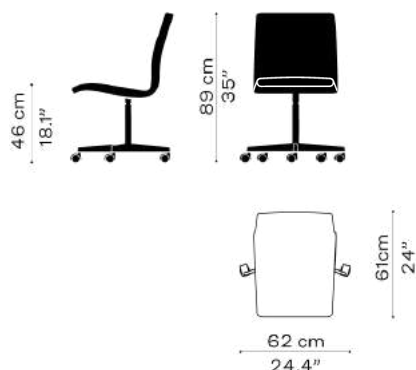

Model: 3171W

Low back
5 Star base on castors
Fixed seat height
Weight: 9,7 kg / 20.7 Lb

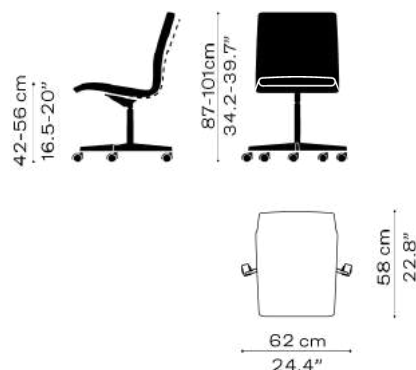

Model: 3191W

Low back
5 Star base on castors
Height adjustable
Tilting mechanism
Weight: 11,5 kg / 25.4 Lb

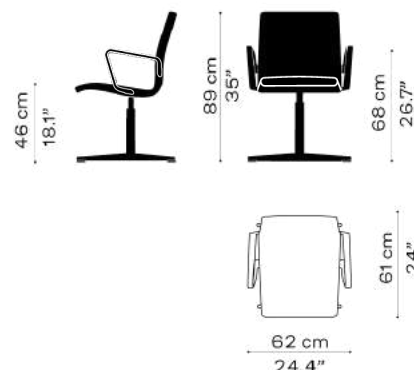

Model: 3241T

Low back
4 Star base
Fixed seat height
Weight: 10,6 kg / 23.4 Lb

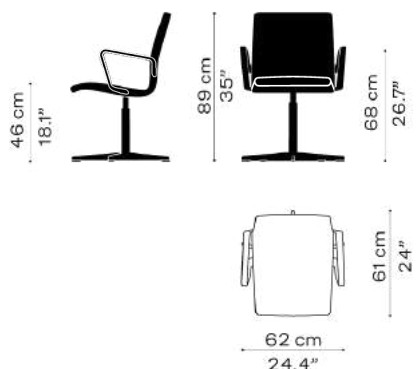

Model: 3271T

Low back
5 Star base
Fixed seat height
Weight: 10,96 kg / 23.7 Lb

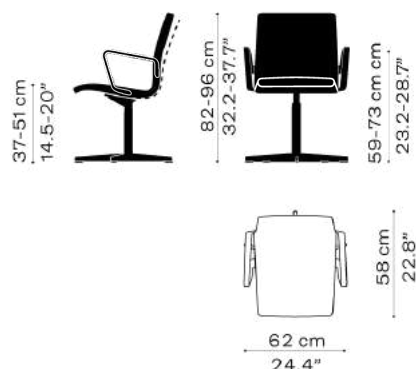

Model: 3291T

Low back
5 Star base
Height adjustable
Tilting mechanism
Weight: 13,2 kg / 29.1 Lb

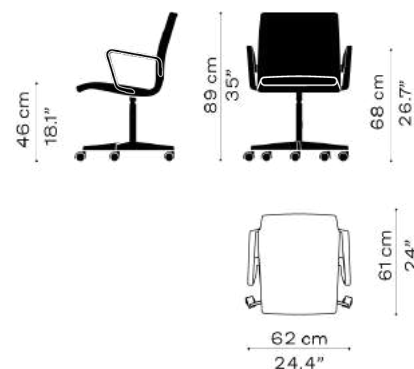

Model: 3271W

Low back
5 Star base on castors
Fixed seat height
Weight: 11,67 kg / 25.7 Lb

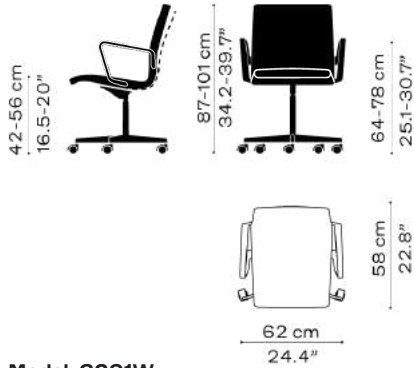

Model: 3291W
 Low back
 5 Star base
 Height adjustable
 Tilting mechanism
 Weight: 8,67 kg / 19 lb

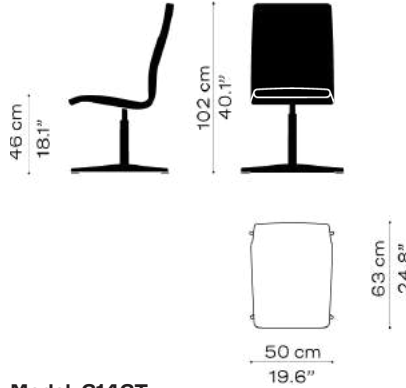

Model: 3143T
 Medium back
 Fixed seat height
 4 Star base
 Weight: 8,85 kg / 19.5 Lb

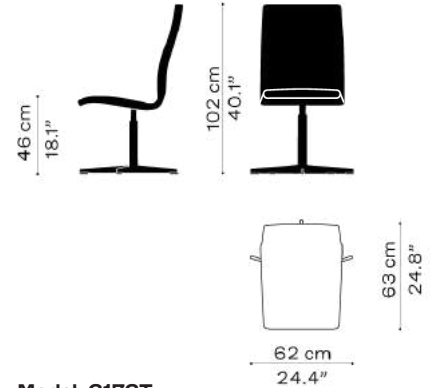

Model: 3173T
 Medium back
 5 Star base
 Fixed seat height
 Weight: 9,22 kg / 20.3 Lb

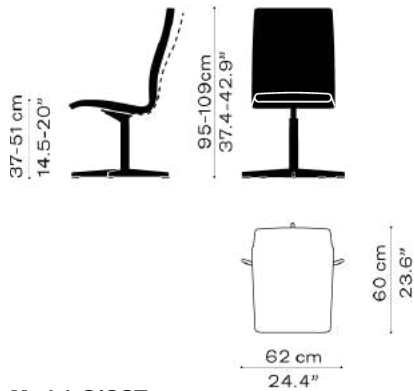

Model: 3193T
 Medium back
 5 Star base
 Height adjustable
 Tilting mechanism
 Weight: 11,35 kg / 25 lb

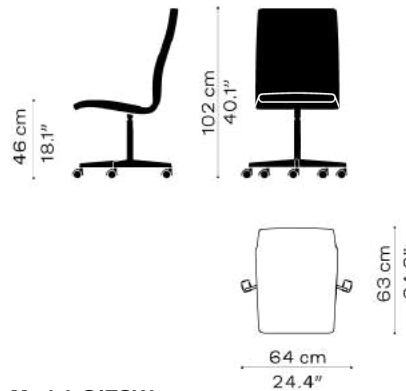

Model: 3173W
 Medium back
 5 Star base on castors
 Fixed seat height
 Weight: 9,93 kg / 21.9 Lb

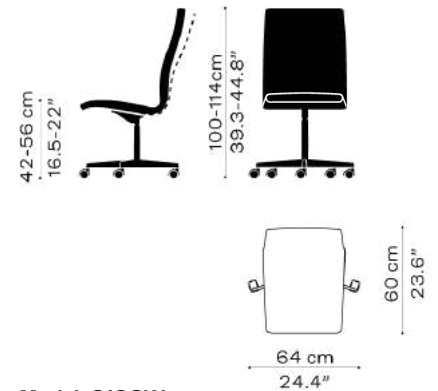

Model: 3193W
 Medium back
 5 Star base on castors
 Height adjustable
 Tilting mechanism
 Weight: 12,05 kg / 26.6 Lb

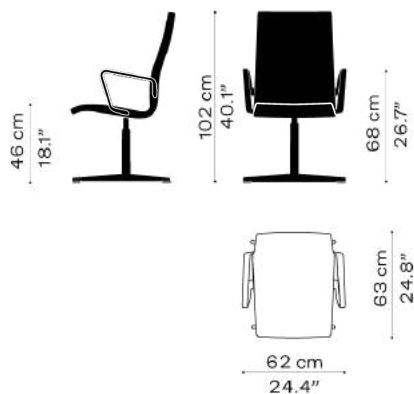

Model: 3243T
 Medium back
 4 Star base
 Fixed seat height
 Weight: 11,14 kg / 24.6 Lb

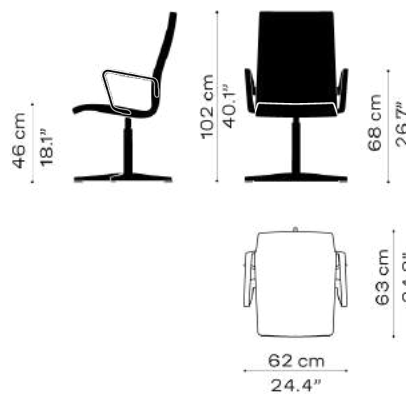

Model: 3273T
 Medium back
 5 Star base
 Fixed seat height
 Weight: 11,51 kg / 25.4 Lb

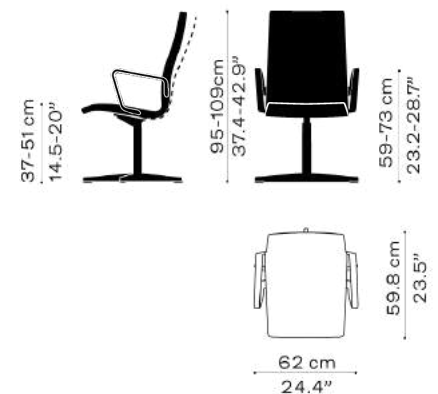

Model: 3293T
 Medium back
 5 Star base
 Height adjustable
 Tilting mechanism
 Weight: 13,64 kg / 30 lb

DIMENSIONS

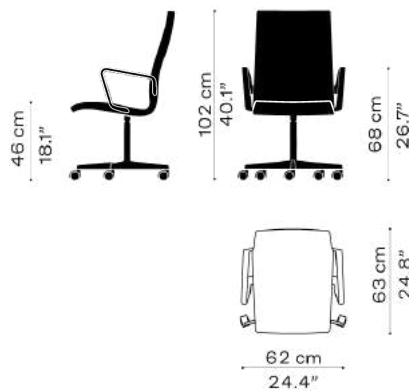

Model: 3273W

Medium back
5 Star base on castors
Fixed seat height
Weight: 12,22 kg / 26.9 Lb
Weight: 14,34 kg / 31.6 Lb

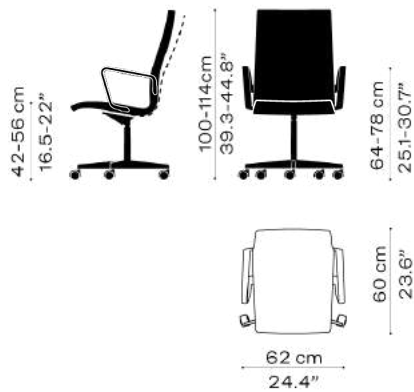

Model: 3293W

Medium back
5 Star base on castors
Height adjustable
Tilting mechanism
Weight: 14,34 kg / 31.6 Lb



Oxford™ chair (3243T) in Embrace concrete grey leather and **Pluralis™** table (KS424) in Walnut 82 veneer and polished aluminium.

PLURALIS™

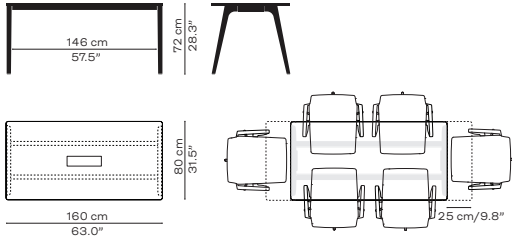

Model: KS420
 Single tabletop
 Available with overhang one- or two end(s) (+25 cm / 9.8")
 Minimum weight: 41 kg / 90 lbn

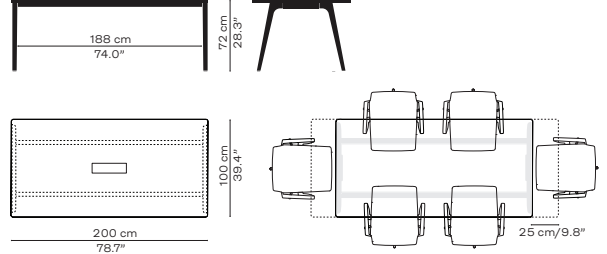

Model: KS421
 Single tabletop
 Available with overhang one- or two end(s) (+25 cm / 9.8")
 Available widths: 80 cm / 31.5", 90 cm / 35.4" or 100 cm / 39.4"
 Minimum weight: 46 kg / 101 lb

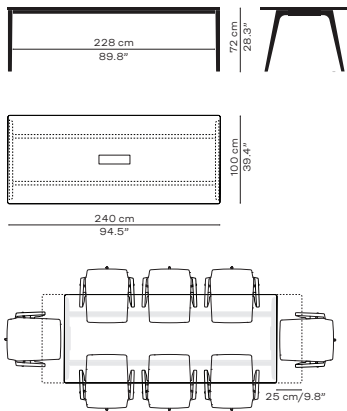

Model: KS422
 Single tabletop
 Available with overhang one- or two end(s) (+25 cm / 9.8")
 Available widths: 80 cm / 31.5", 90 cm / 35.4", 100 cm / 39.4" or 120 cm / 47.2"
 Minimum weight: 52 kg / 115 lb

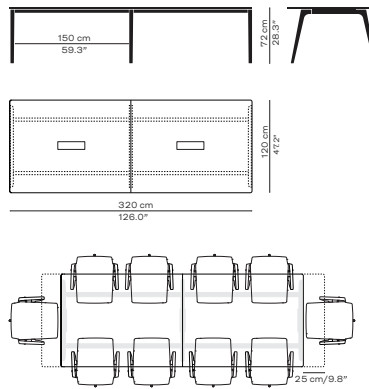

Model: KS423
 Two tabletops
 Available with overhang one- or two end(s) (+25 cm / 9.8")
 Available widths: 80 cm / 31.5", 90 cm / 35.4", 100 cm / 39.4" or 120 cm / 47.2"
 Minimum weight: 73 kg / 161 lb

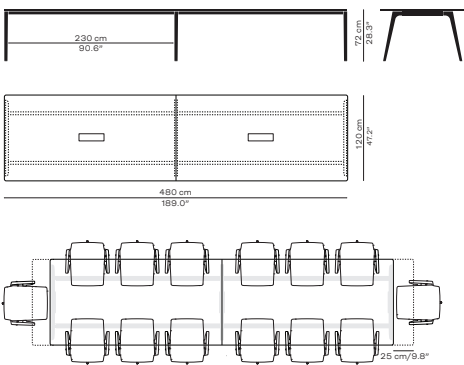

Model: KS424
 Two tabletops
 Available with overhang one- or two end(s) (+25 cm / 9.8")
 Available widths: 80 cm / 31.5", 90 cm / 35.4", 100 cm / 39.4" or 120 cm / 47.2"
 Minimum weight: 96 kg / 212 lb

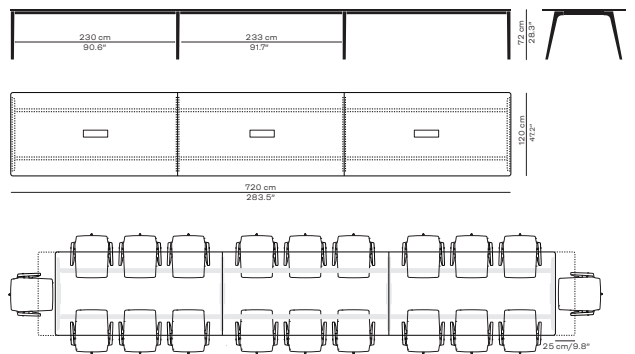

Model: KS425
 Three tabletops
 Available with overhang one- or two end(s) (+25 cm / 9.8")
 Available widths: 80 cm / 31.5", 90 cm / 35.4", 100 cm / 39.4" or 120 cm / 47.2"
 Minimum weight: 139 kg / 306 lb

FLEXIBLE SEATING WITH WHEELS

DISCOVER MORE

Rethinking tomorrow's workspace, Fritz Hansen's range of office furniture is designed with aesthetics and function in mind, for lifted wellbeing and productivity. Explore our portfolio of furniture for workspaces at our website fritzhansen.com



NO2™ Recycle (NO2-30/31) in Grey and Light Blue plastic and polished aluminum and **Pluralis™** (KS420) in Oak, 72, veneer and polished aluminum.



N02™ RECYCLE
 Model: N02-30
 Material: Plastic
 Design: Nendo, 2019



N02™ RECYCLE
 Model: N02-31
 Material: Plastic
 Design: Nendo, 2019



SERIES 7™
 Model: 3117
 Material: Full Uph. (Cat. 5)
 Design: Arne Jacobsen, 1955



LITTLE GIRAFFE™
 Model: 3211,
 Material: Leather
 Design: Arne Jacobsen, 1959/2018



GRAND PRIX™
 Available upon request
 Material: Full Uph.
 Design: Arne Jacobsen, 1957



SERIES 7™
 Model: 3217
 Material: Front Uph. (Cat. 3)
 Design: Arne Jacobsen, 1955



GRAND PRIX™
 Available upon request
 Material: Oak
 Design: Arne Jacobsen, 1957



LITTLE GIRAFFE™
 Model: 3211,
 Material: Uph. (Cat. 1)
 Design: Arne Jacobsen, 1959/2018



SERIES 7™
 Model: 3117
 Material: Full Uph.
 Design: Arne Jacobsen, 1955

PRODUCTS MADE TO LAST

Drawing on a history of collaborations with some of the world's most brilliant designers, Fritz Hansen furniture is made to last through generations. Durability is a fundamental consideration in our designs.



In front **Little Giraffe™** (3201) in Walnut leather and black base, **Plenum™** Sofa (JH1003) in Capture 6001 and **Little Friend** (KS12) in Walnut veneer and black base.

GET THE FILES YOU NEED

Fritz Hansen offers a wide range of furniture for the modern workspace. Discover our portfolio and get inspired at fritzhanzen.com

At our Downloads site, you can find 2D, 3D and revit files to support your project. Discover more here: downloads.fritzhanzen.com

HEADQUARTERS

FRITZ HANSEN A/S
Allerødvej 8
3450 Allerød
Denmark
Tel: +45 48 17 23 00

GET IN TOUCH

SALES - ASIA & OCEANIA
customerserviceasia@fritzhanzen.com
Tel: +81 3 3400 3316

SALES - EUROPE
salesupport@fritzhanzen.com
Tel: +45 70 80 70 90

SALES - NORTH AMERICA
info@fritzhanzen.com
Tel: +001 212 219 3226

PRESS - GLOBAL
press@fritzhanzen.com

LEARN MORE

NEWSLETTER
Sign up at:
fritzhanzen.com/newsletter

DOWNLOADS
Find 2D & 3D files, imagery,
product facts and much more at:
downloads.fritzhanzen.com

INSTAGRAM
[@fritzhanzen](https://www.instagram.com/fritzhanzen)

PINTEREST
Fritz Hansen™

FACEBOOK
Fritz Hansen

LINKEDIN
Fritz Hansen

FRITZ HANSEN

DESIGN COLLECTION

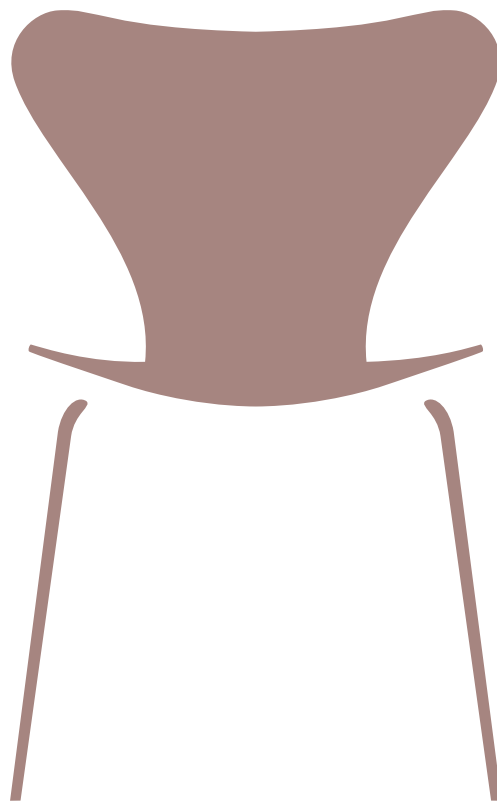

FURNITURE LIGHTING ACCESSORIES

EXTRAORDINARY DESIGN SINCE 1872

Welcome to a world of design, craftsmanship and beauty. Here, you'll find more than 100 years of Danish design tradition and collaborations with visionary architects, designers and artists from around the world.

Welcome to Fritz Hansen.

Since 1872, Fritz Hansen has been crafting extraordinary design that transforms the everyday into something special. By continuously pushing the boundaries of design and craftsmanship we shape the world for those who wish to be inspired, intrigued and surprised.

THIS IS NO ORDINARY DESIGN

Founded in Denmark in 1872, Fritz Hansen is a global leader in furniture, lighting and accessory design and production. Driven by a passion for beauty, quality, and craftsmanship, the company embodies a modern, Nordic lifestyle and collaborates with visionary artists, designers, and architects from around the world. The brand has collaborated with Arne Jacobsen, Cecilie Manz, Hans J. Wegner, Piero Lissoni, and Poul Kjærholm, among others.

Today Fritz Hansen designs are sold in more than 85 countries through 2,000 points of sale, including flagship stores in Copenhagen, San Francisco, New York and Tokyo. The company employs approximately 260 people worldwide and maintains its headquarters north of Copenhagen, serving design-passionate customers through contract and retail.



Egg™ lounge chair by Arne Jacobsen in Vidar textile.



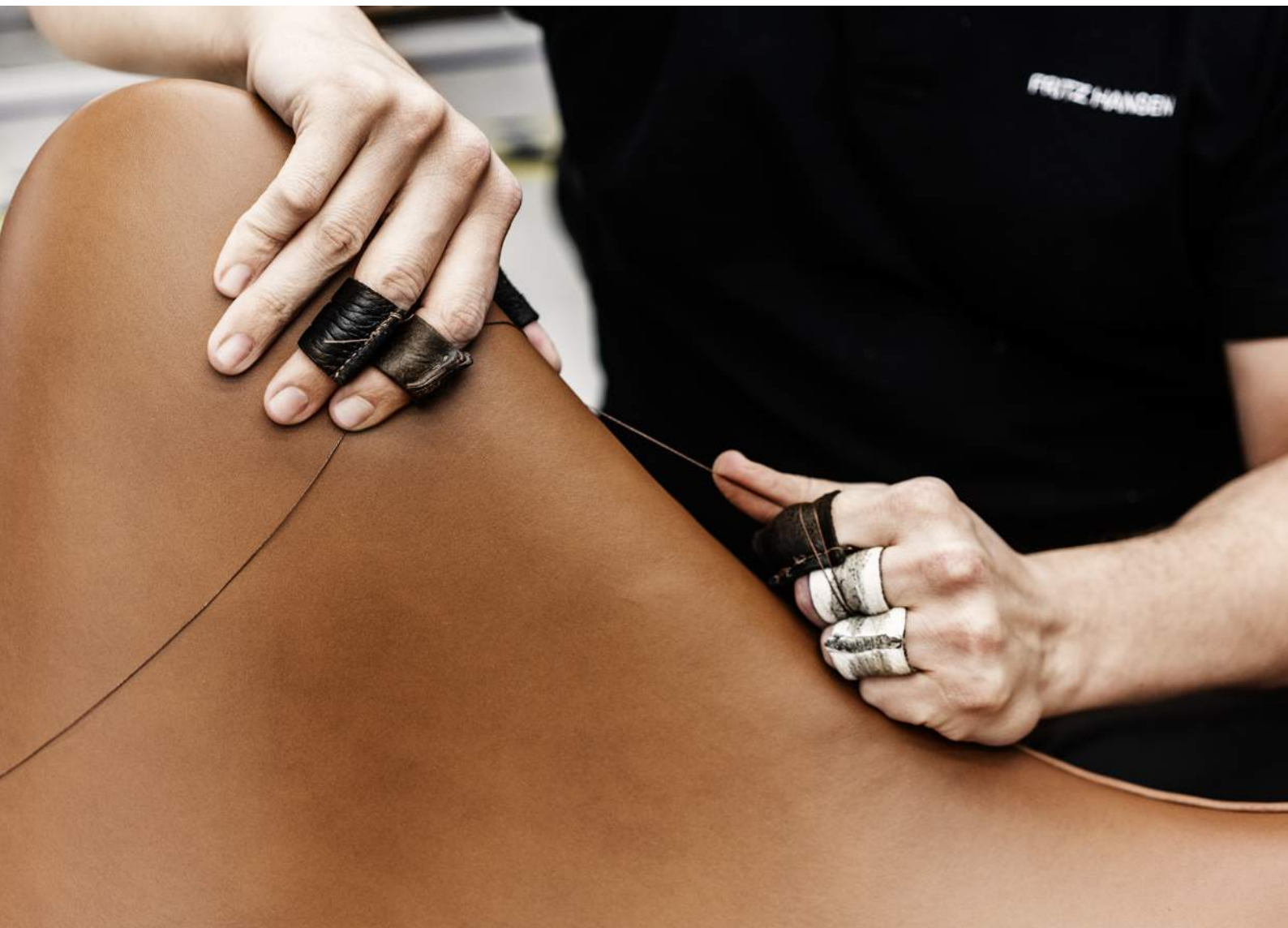

LONGEVITY & SUSTAINABILITY

We believe that premium quality and sustainability go hand in hand.

At Fritz Hansen, we are working with social, environmental and economic considerations to find sustainable solutions, without compromising on quality.

From careful sourcing to operating our own factory on green electricity, we believe the details matter - in design and process.

LIFELONG LOVE AFFAIR

Do natural imperfections make great designs more beautiful?

Opinions of beauty are linked to people's deepest desires and inherent values, which is perhaps why they can often seem so strong and visceral. That, too, is simply natural. Attitudes towards the natural wear of materials differ too. Patina and the natural beauty marks displayed over time on materials such as metal, stone and leather are admired by some and disliked by others.

In some cases, vintage furniture designs with patina are prized by collectors for their uniqueness. The visible age of a given piece becomes a source of pride; its changes are a natural and poetic reminder that nature is mutable. On the other hand, the desire for consistency is natural too, and linked to peace of mind. Some prefer slower change and less sensitivity from the space around them, favouring an evergreen look with materials that have been coloured and treated to stay relatively consistent over time.

The beauty of objects is how different they are from us, how they stand still and steady in the everchanging world. Differences of opinion and in preference are, after all, only natural.





Lily™ chair by Arne Jacobsen in walnut veneer and the **Superellipse™** table with span legs by Bruno Mathsson and form by Piet Hein.

CLASSIC DESIGN

A Danish design bridges Chinese antiquity
and new Nordic taste.

The China Chair™ was designed by Hans J. Wegner in 1944. Inspired by the timeless aesthetic of ancient Chinese design in the 17th and 18th centuries, the China Chair epitomises his lifelong quest to understand the nature of wood and explore its possibilities. In this modern interpretation, he unfolded his talent as a wood craftsman and his flair for expressive and sculptural functionalism.



China Chair™ designed by Hans J. Wegner in cherry wood



Decorative objects gather behind a living room door as the **China Chair™**, designed by Hans J. Wegner, sneaks into the frame.

SIMPLE ELEGANCE



Poul Kjærholm & Fritz Hansen

A trained cabinetmaker who completed his studies at the Danish School of Arts and Crafts, Poul Kjærholm had a particular interest in construction materials – especially steel, which he considered a material deserving the artistic respect that was commonly awarded to wood.

Poul Kjærholm initiated a collaboration with furniture manufacturer Ejvind Kold Christensen in 1955, which continued for the rest of Kjærholm's life with the two families remaining close to this day.

Two years after the designer's death, the Kjærholm trustees entrusted Fritz Hansen with the production and sales of The Kjærholm Collection – designs developed by Poul Kjærholm from 1951 to 1980.

Fritz Hansen is honoured to continue production and to distribute Poul Kjærholm's furniture to architects and private customers around the world.





A **PK22™** chair in wicker and **PK61™** coffee table in satin-polished stainless steel and grey brown honed marble by Poul Kjærholm, with an **Ikeru** vase by Jaime Hayon.



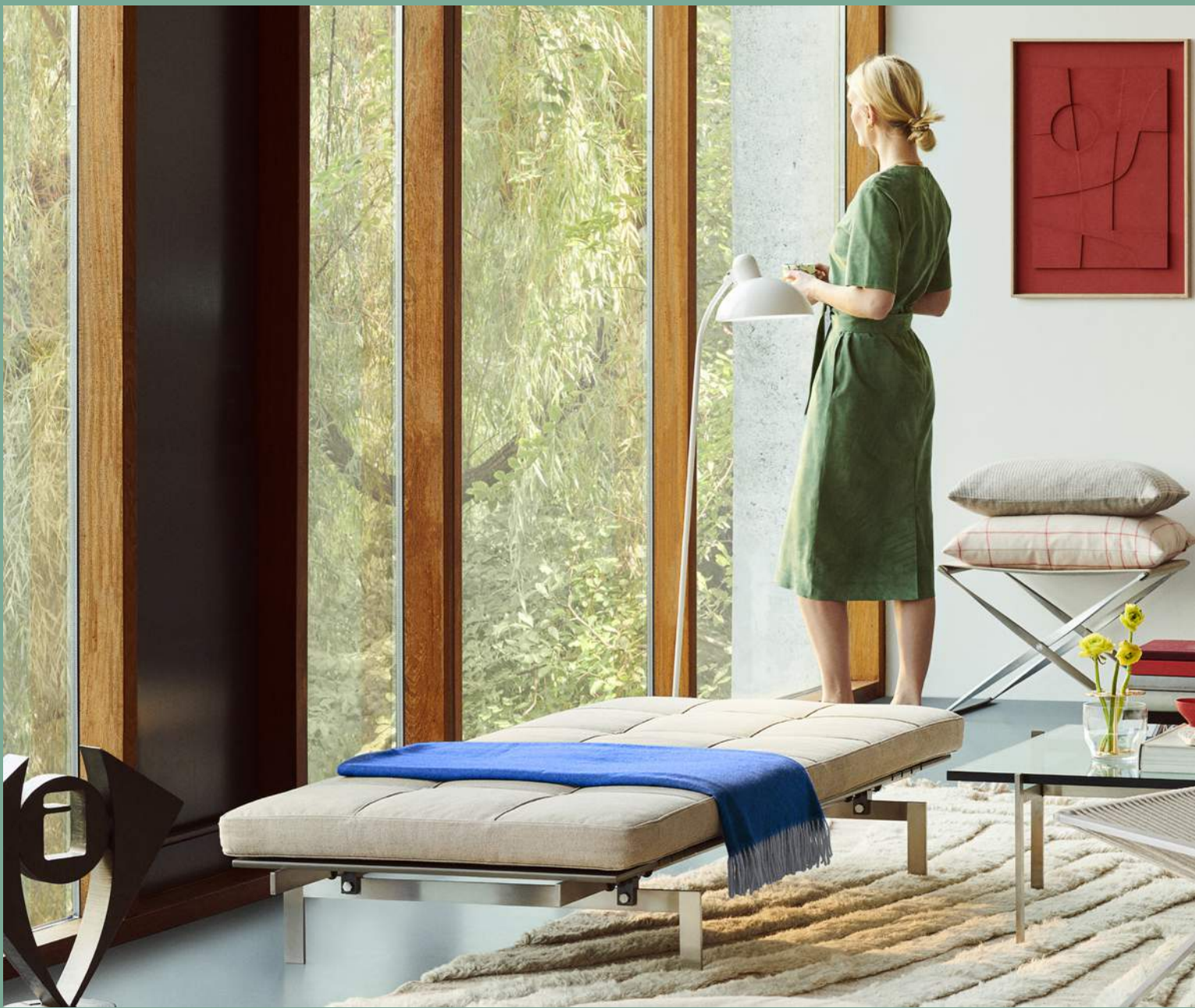

PK80™ daybed, **PK61™** coffee table, **PK25™** chair, **PK91™** folding Stool, all by Poul Kjærholm. **Planner™** shelving by Paul McCobb, a **KAISER idell™** floor lamp by Christian Dell and **Ikebana** vase by Jaime Hayon also shown.

PK80™ daybed
designed by Poul Kjærholm
in canvas.



TRANSPARENT DESIGN

For Poul Kjærholm, simplicity was essential. He insisted on materials of the highest quality and designed for transparency. Indeed, nothing in Kjærholm's designs is unnecessary or cosmetic.



PK61™ coffee table designed by Poul Kjærholm in satin-polished stainless steel and glass.

LUXURY LIVES ON

True luxury withstands the test of time in terms of design and craftsmanship. Whether from the great masters of furniture design or the rising stars of tomorrow, Fritz Hansen seeks to continue the design traditions of the past while creating the next generation of design classics for the future.



PK9™ chair and **PK54™** table designed by Poul Kjærholm under an **Orient™** pendant by Jo Hammerborg.





Arne Jacobsen's luxurious **Lily™** chair in Walnut catches the sunlight in Tokyo.

NEW BASICS

Bases are available in Chrome, Black, Nine Grey, Brown Bronze, Silver Grey, Warm Graphite and White, supporting dining, meeting and task seating.

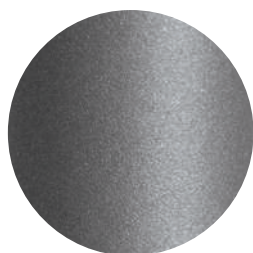

SILVER GREY

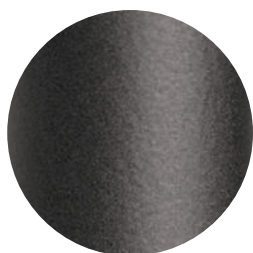

WARM GRAPHITE

Match the chair bases* with other Fritz Hansen furniture bases, including the Table Series, stacking chairs, Egg™ and Swan™ chairs by Arne Jacobsen, and the Lissoni Sofa™ Series.

This creates a system of Fritz Hansen colours and finishes that can be used across an entire project.

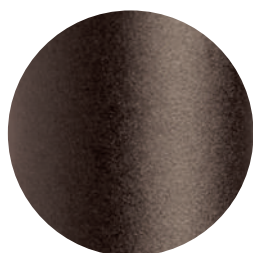

BROWN BRONZE

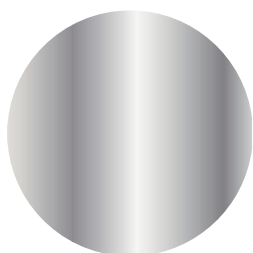

CHROMED /
POLISHED STEEL

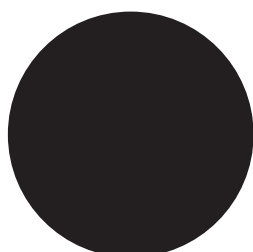

BLACK

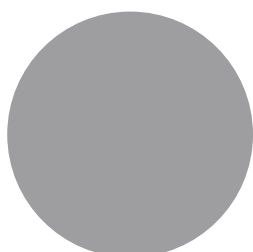

NINE GREY

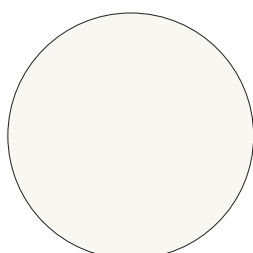

WHITE

* The colour availability differs depending on the products.



The **Egg**™ chair by Arne Jacobsen adds organic curves to an interior design.



Series 7™ chair by Arne Jacobsen in lacquered Light Beige with Warm Graphite base and front upholstery. Black **Superellipse™** table under grey **Caravaggio™** lamp by Cecilie Manz.

NEW NORDIC DINING

The eye-catching Caravaggio™ pendant was launched in 2005 and instantaneously gained status as a design icon. With its simple, elegant and recognisable shape it has set the standard as a new classic in lighting design.



Black **Superellipse™** table
by Piet Hein, Bruno
Mathsson & Arne Jacobsen
with laminate table top and
Warm Graphite base.



A SENSE OF COLOUR



16 CAREFULLY CURATED COLOURS

Carefully curated in collaboration with Carla Sozzani, each colour has been developed to not only complement the natural materials of the designs, but to also complement each other.

Explore a new palette of sixteen compatible colours and seven bases for Ant™, Grand Prix™ and Series 7™ chairs by Arne Jacobsen.





LIVING WITH COLOURS

A stunning new dimension of colours and textiles for the iconic Series 7™ chair by Arne Jacobsen. Create your very own unique combination and add a touch of colour to any home and any room.





A HINT OF GREEN

Series 7™ chair by Arne Jacobsen in Evergreen with Brown Bronze base and front upholstery in Sunniva 3.

A DASH OF YELLOW

Series 7™ chair by Arne Jacobsen in True Yellow with Brown Bronze base and front upholstery in Remix 2.

ADMIRING ARNE JACOBSEN

Why the Italian editor, gallerist and businesswoman
Carla Sozzani collects Arne Jacobsen design.

Carla Sozzani is well known as the founder of 10 Corso Como, the Milanese concept store – and quite possibly the first of its kind in the world – which she founded in 1991. She is also a gallerist and editor, having worked with the likes of Bruce Weber and Herb Ritts and collaborated with Azzedine Alaïa and Rei Kawakubo. She has curated exhibitions with Annie Leibovitz, Helmut Newton, David La Chapelle and Steven Meisel in her own gallery and at the Maison Européenne de la Photographie in Paris, among other locations. What many don't know is that Sozzani is also a long-time admirer and collector of Danish design.

Her fascination with Arne Jacobsen's work began in the '70s and has continued for almost 50 years. Today, Arne Jacobsen chairs can be found at 10 Corso Como, Sozzani's studio, and in her home.

'Harmony is the secret of any environment, and it only develops over time. For me it is like this: I can add more and more Eggs, Swans, Drops or Series 7 to my interiors, while at the same time they appear as if they were there for the first time or always. You see?' she says.

The organic shape of Arne Jacobsen designs captivates Sozzani, who describes the Series 7 chair as 'sensual.' The design, she explains, is so organic that it is almost like a human form. You can dress it up in any colour and it takes on a new attitude.

Sozzani pulls out her iPhone to share photographs of pieces from her personal collection, and a rare, vintage Jacobsen design that she is currently hunting for.

*Carla Sozzani has collaborated with Fritz Hansen on a new palette of 16 colours for iconic Arne Jacobsen designs, released in 2020.





ADD A TOUCH OF COLOUR TO ANY ROOM

Green, blue, pink, brown, red or yellow? Whatever your desired expression, Arne Jacobsen chair designs can reflect the sentiment with sixteen carefully curated colours and seven base options.



Grand Prix™ chair in True Yellow with Warm Graphite base and **Circular™** table in Walnut veneer by Arne Jacobsen. The grey **Suspence™** pendant is designed by GamFratesi.





Drop™ chair in Olive Green
with Warm Graphite base

THE REBELLIOUS ARNE JACOBSEN



Arne Jacobsen & Fritz Hansen

It is said that as a child growing up in Copenhagen, Arne Jacobsen painted over the Victorian wallpaper in his bedroom. But young Arne did not cover his walls with typical childish drawings or paint the ornate wallpaper boyish blue. Instead, he decided to paint his room entirely white.

His decision may seem commonplace today, but in the early twentieth century white walls were not yet in fashion. From the very beginning, Arne Jacobsen was ahead of his time.

For more than half of the twentieth century, Arne Jacobsen's ideas shaped the landscape of Danish design, rippling out from Scandinavia to influence architects and designers around the world. He directed projects ranging from complex buildings like Denmark's National Bank to meticulous challenges as humble as a special teaspoon for his cutlery set, working with a relatively small studio staff driven by an unquenchable desire to create.

Jacobsen's creative process centred on his strict consideration of detail. He brought his visions to life for patrons and builders with scrupulous, hand-painted watercolour sketches. In any given year, Jacobsen managed to design what others might be happy to produce in five.



A PEARL OF LIGHT



Clam™ pendant, designed by Ahm & Lund shown together with **PK54™**, **PK54A™** and **PK9™** by Poul Kjærholm.

Crafted in mouth blown glass and brass, the Clam™ pendant designed by Ahm & Lund is a modern lighting innovation with a timeless aesthetic.



Mouth blown opal glass and brushed brass come together – and move apart – to create elegant, adjustable and atmospheric lighting for dining and

living spaces. Equally elegant open as it is closed, the perfectly balanced design elevates any room with its considered combination of form and ambience.



The **Fred™** lounge chair, designed by Jaime Hayon, is assembled by hand. The low, open profile and curved armrests invite relaxation.

Fred™ lounge chairs by Jaime Hayon draw inspiration from the pelican's broad wings, gently curved body and distinctive bill. The sculpted frame of the chair is crafted from eight individual pieces of wood, digitally cut before being carefully finished and assembled by hand.

All wooden chair frames are FSC-certified. Christianshavn™ textiles add another dimension of sustainability with EU Ecolabel and OEKO-TEX® STANDARD 100 certifications.



THE ART OF LOUNGING

‘Comfort was a key factor, as was the combination of the best of Danish design craftsmanship and modern technology,’ says Jaime Hayon about the new Fred™ lounge chair, featured here in clear lacquered oak.



Lune™ sofa and Fred™ chairs designed by Jaime Hayon in Pink 1131 Christianshavn™ fabric surround a Planner™ coffee table designed by Paul McCobb.







Ro™ chair and footstool designed by Jaime Hayon, a **KAISER idell™** floor lamp with a **Rug** designed by Cecilie Manz underfoot.



A **Ro™** footstool is the perfect place to put your feet up.



Leather **Egg™** chair
by Arne Jacobsen and
Fritz Hansen-designed
Tray Table.



AJ Trolley by Arne Jacobsen.





The modular **Alphabet Sofa™** series by Piero Lissoni offers flexible comfort. Arrange at will to create a unique space.



Lissoni Sofa™ by Piero Lissoni in Christianshavn fabric and black base.

ELEGANT BY DESIGN

Characterised by clean lines and flawless attention to detail, the Lissoni Sofa™ series has a distinct aesthetic that elevates and adds character to any room and from any angle.





Lissoni Sofa™ by Pierro Lissoni in Remix fabric and Warm Graphite base.

Fri™ chair by Jaime Hayon,
and **KAISER idell™** floor lamp.

HOME ACCORDING TO JAIME HAYON



Jaime Hayon
Hayon Studio

WHAT DEFINES GOOD DESIGN?

‘Good design is primarily design that lasts. Design must have something to say; it must be able to improve our quality of life and be meaningful. But for me, design is not just about function – it’s also about feelings, and I like if it provokes a little and can challenge our way of life.’

WHAT MAKES A SPACE FEEL LIKE HOME?

‘A room is homey when the lighting and the atmosphere come together; when the music matches the place, and when the combination of colours and light makes me feel happy. I also like to be able to feel what is happening outside. I don’t like being in pent up spaces, where daylight is excluded or where materials and furniture are cold, or where I get cold feet.’





Planner™ coffee table
by Paul McCobb.

PLANNER™ DESIGNS

Paul McCobb's innate understanding of perspective paved the way for a career as one of the most important design figures of his time. The self-taught designer's pragmatic yet perfectionist nature was reflected in his work, characterised by slender, graphic lines, a simplicity of form and lightness of design.



Magazine Holder by Paul McCobb.



PM-02 table lamp
by Paul McCobb.



Planner™ coffee table by Paul McCobb together with
Cross-Plex™ lamp by Bodil Kjær.



Planner™ shelving by Paul McCobb.



KAISER idell™ Luxus by Christian Dell in brass and matt black is a bold pairing of reflective warmth and cool darkness.



EMBRACING MODERN LIFE

The N01™ chair fuses Danish and Japanese design sensibilities into nine layers of pressure-moulded veneer and solid wood legs. Millimetre by millimetre, the design is an illustration of beauty and functionality. Available in beech, oak and black lacquered oak.



N01™ armchair in black coloured oak by nendo.



Suspence™ pendant by GamFratesi over the **Superellipse™** table by Piet Hein, Bruno Mathsson & Arne Jacobsen and **NO1™** chairs in oak by nendo.



An **Essay™** table by Cecilie Manz in natural oak, surrounded by **Series 7™** chairs by Arne Jacobsen in Dusk Blue, Midnight Blue and Lavender Blue with coloured bases.



A PROFOUND SENSE OF DETAILS

Cecilie Manz's universe revolves around her love of art, and the names of her products often pay tribute to her favourite creative minds.



Cecilie Manz

Over the course of her career, Danish designer Cecilie Manz has shown an impeccable ability to create lamps, ceramics, home accessories and furniture design that continually unite the Scandinavian tradition of simplicity with a modern, international expression.

While her work tends to abide by the 'form follows function' philosophy, each design is also imbued with a serene beauty. Pieces are understated yet present themselves to the world with an artistic twist.

REMARKABLY ELEGANT



FH125 table for city life and smaller spaces.



Ant™ chairs by Arne Jacobsen in Ever Green, Olive Green and White with coloured bases together with **Calabash™** pendants by Komplot Design.



INSPIRED BY IKEBANA

'Ikebana is often translated to Japanese floral art or flower arrangement,' says Tomoko Sempo Yanagi, an Ikebana professor and the chairperson of Ikenobo UK & Ireland, 'But, in my view, Ikebana isn't just an artistic arrangement of flowers and plants, the practice is as spiritual as it is technical.'



Ikebana vases by Jaime Hayon come in three variants.



Ikebana Small vase designed by Jaime Hayon.

Dating back to the seventh century when Buddhists started offering flowers at temple altars, ikebana was later formalised in the 16th century by emperors and aristocrats. The practice also has roots in the ancient Shinto religion – a belief system that conceives ‘god,’ or ‘spirits,’ as residing in natural phenomena such as trees, flowers and wind. Today, the art form is practiced by professionals and amateurs alike.

At its core, ikebana involves carefully selecting plants and flowers to create a form that honours natural characteristics when placed in a new environment.

Ikebana and Ikeru vases by Spanish designer Jamie Hayon are created in the spirit of the practice and its meditation on nature. The modern vases are designed to honour every flower placed within them, from stem to crown.



Ikeru High vase
by Jaime Hayon.



Night Owl™ table lamp
by Nikolai Wiig Hansen

SMALL AND STYLISH

Elevate the everyday for a little one with extraordinary design on a smaller scale. Children's chairs by Arne Jacobsen in a variety of colours and Happy Hooks by Jaime Hayon are two popular picks for design enthusiasts in the making.

Happy Hook coat hanger by Jaime Hayon.





Series 7™ children's chair by Arne Jacobsen in coloured ash together with **Rug Ochre** by Cecilie Manz and **Happy Hook** by Jaime Hayon.

Maluma™ pendants
designed by Fumie Shibata.



BRIGHT IDEAS

Pleasant interior lighting shapes mood, improves productivity and conserves energy. Scandinavian winters are long and dark and summer days are long and bright. Fritz Hansen's collection of timeless lighting design focuses on overall impact: turned on or left off, indoor lighting should be beautiful.





The harmonious and striking **Aeon Rocket™** pendant, designed by Morten Voss.

AESTHETIC AMBIENCE

Concert™ is world-famous, Danish design. The unique shade configuration is visually characteristic of architect Jørn Utzon's design ethos.

The pendant's diffuser is handcrafted using triple-layered, mouth-blown opal glass and distributes pleasant, even light to make it a noteworthy centrepiece for dining rooms and other gathering places.



Cross-Plex™ lamp designed by Bodil Kjær.





The multi-layered **Concert™** pendant showcases Jørn Utzon's architectural language.



Leather **Buckets** by Mia Lagerman
on the **Pluralis™** table by Kasper Salto.



Oxford™ chair by Arne Jacobsen and
the **Pluralis™** table by Kasper Salto,
with **KAISER idell™** table lamp next to
Planner™ shelving by Paul McCobb and
and **Pouf** by Cecilie Manz.

WORKING HOURS

The right work setup can assist focus, improve posture and make working hours more productive – and pleasant.







Leather **Series 7™** chair by Arne Jacobsen with swivel base and **Pluralis™** table by Kasper Salto, with **Planner™** shelving by Paul McCobb and **KAISER idell™** table lamp by Christian Dell.



Classic Throw on the **PK63™** coffee table by Poul Kjærholm.

Coat Tree™ Wall
by Sidse Werner in dark blue.



Pouf, in two sizes, and **Rug** by Cecilie Manz.



High Dot™ in leather,
designed by Arne Jacobsen.

Candleholder in stainless steel
designed by Jaime Hayon.



THE LITTLE THINGS

At home and work, accessories add beauty and life to our interiors. Fritz Hansen accessories always marry form and function with high quality craftsmanship.

Slide storage
designed by Karin Nakamura.



Stub table by Mette Schelde
together with **Let™** lounge chair
by Sebastian Herkner.

Stub table
by Mette Schelde in coloured
ash with glass table top.





STAY AWHILE

Let™ lounge chairs by Sebastian Herkner profile the German designer's skills and aesthetic and Fritz Hansen's expert craftsmanship.

HOUSEHOLD PLASTIC WASTE REDESIGNED

A multi-purpose chair made from recycled plastic household waste that can be recycled once more wherever PP5 plastic bottles are accepted. Learn more at www.fritzhansen.com



N02™ Recycle seating by Nendo in monochrome colour with **Super-Circular™** cafe tables from the Fritz Hansen **Table Series™**.





The **NO2™ Recycle** is Fritz Hansen's first chair made with a circular plastic shell.

TAKE IT EASY

A good chair is one of life's little luxuries, essential for long visits, enjoying a drink or getting work done. Fritz Hansen seating is tested for quality and comfort, designed with precision to fit beautifully into everyday life and spaces.



Arne Jacobsen's **High Dot™** bar stools for the bar or kitchen counter.



Pot™ chair by Arne Jacobsen is a timeless example of embracing comfort.



VIA57™ chairs designed by Bjarke Ingels and KiBiSi,
Tray Table by Fritz Hansen and **Little Friend™** by Kasper Salto.



Little Friend™ table by Kasper Salto is the ideal resting place for a laptop or morning mug of coffee. Easy to move and always useful.

PLENUM™

Plenum™ one-seater by Jaime Hayon is adjustable to your work environment, with optional power plugs, USB outlets (available in select countries) and side tables.





Plenum™ two-seater by Jaime Hayon.

RESTORATIVE BREAKS

Can contentment be designed? What about productivity or happiness? Much is out of our control, but we can set the scene for good conversations, great meetings and restorative breaks. A good seat is the first step.

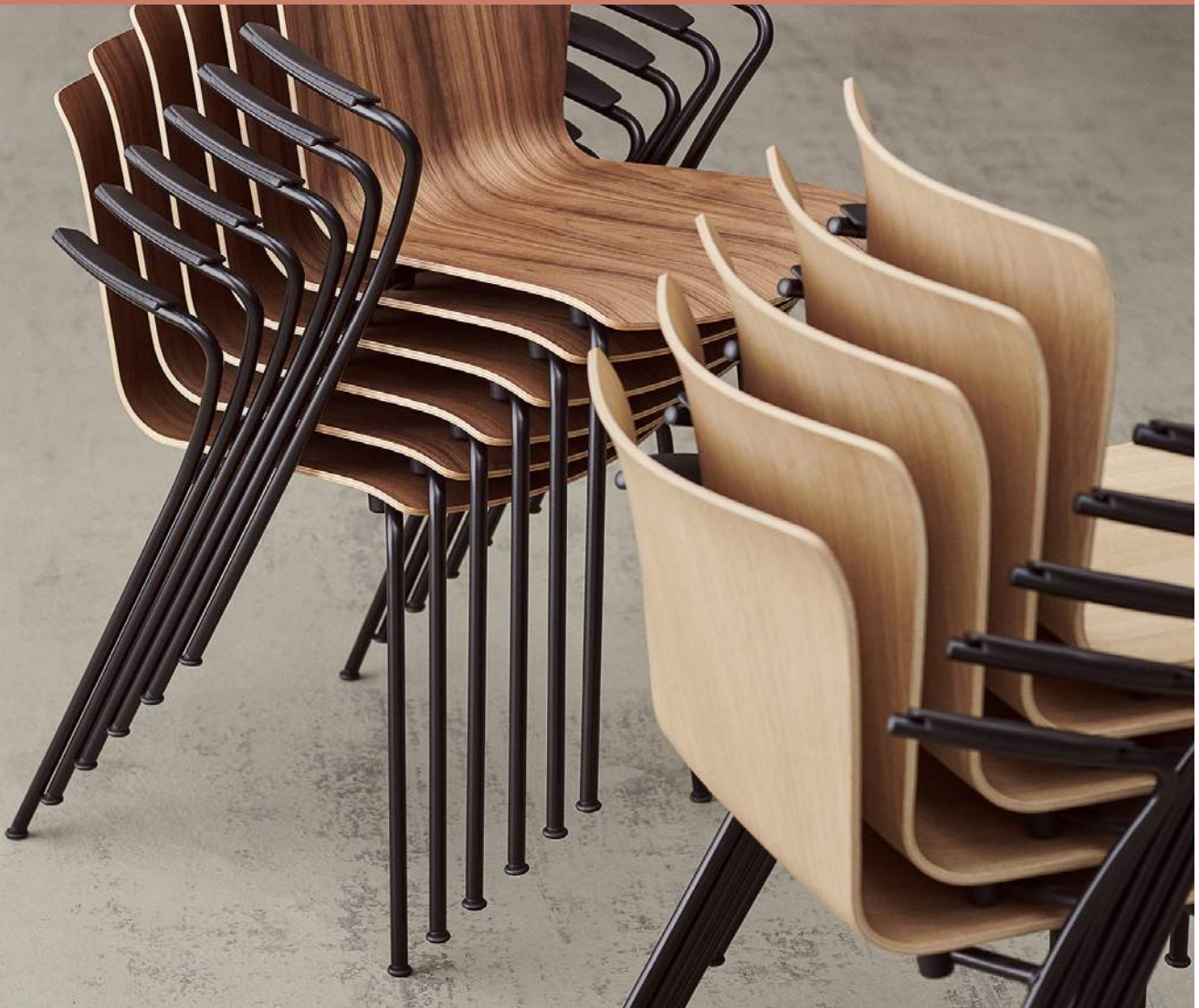



Vico Duo™ chair by Vico Magistretti.

ROOM FOR IMAGINATION





PROJECTS



SKY PATIO BY RYUNIQUE

Location: Dongtan, South Korea
Category: Hospitality
Area: Retail
Architect: Conran & partners

Products: Series 7™, Egg™, Swan™, Ro™, Fri™, Drop™, Grand Prix™, Suspence™, Planner™, Table Series™





VIA57™ seating and large **Caravaggio™** pendants in the Media Library of Capucins.

MEDIA LIBRARY OF CAPUCINS

Location: Brest, France
Category: Culture
Areas: Public area, Library
Architect: Canal (atelier d'architecture)

Products: VIA57™, Caravaggio™



Photos: Thomas Lang

LEGO HOUSE

Location: Billund, Denmark
Category: Culture
Areas: Dining, Restaurant
Architect: Bjarke Ingels Group
Products: Grand Prix™

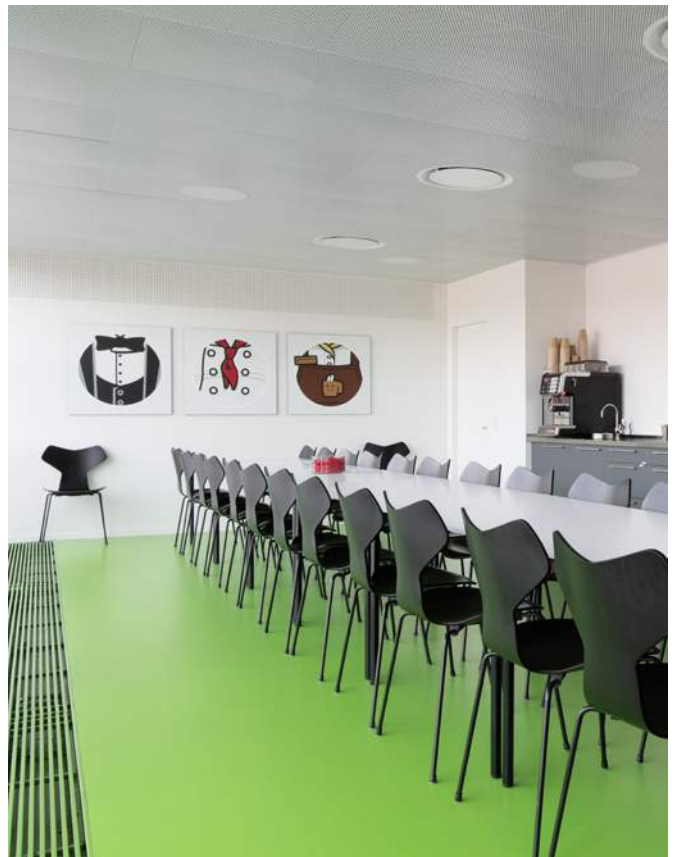

XIAN MAIKE CENTRE BOOKSTORE

Location: Xi'an, China

Category: Culture/Hospitality

Areas: Public area, Library

Interior design: Tomoko Ikegai (ikg.inc.)

Products: Swan™, Coffee Table Series



Swan™ seating
by Arne Jacobsen
mirrors the curves
of the central staircase.



Credit: Designer: Tomoko Ikegai (ikg inc.), Photographer: Nacasa&Partners, Design cooperation: A Factory inc. / Japan Power Media Co, Ltd., Lighting: Sola Associates, Graphic Design: ujdesign.



AGERN

Location: New York, United States

Category: Hospitality

Areas: Restaurant

Architect: Christina Meyer Bengtsson

Products: Grand Prix™, Orient™



Grand Prix™ seating is geometric, offsetting the wood paneling at the restaurant Agern in New York.

KEUNE HAIRCOSMETIC

Location: Tbilisi, Georgia
Category: Retail/Healthcare
Areas: Clinic

Products: Fri™, Ro™, Favn™,
Series 7™



Fritz Hansen seating by Jaime Hayon and Arne Jacobsen adds quiet charm in soft colours.



CARLSBERG

Location: Copenhagen, Denmark
Category: Office
Areas: Canteen, Boardroom, Meeting rooms
Architect: Vivianna Schøttz Andersen,
C.F.Møller

Products: Grand Prix™, Little Giraffe™





OFENHAUS

Location: Augsburg, Germany
Category: Hospitality
Areas: Restaurant & Bar
Architect: Innenarchitektur Büro Kolb

Products: Pot™, Caravaggio™, Series 7™

Pot™ and **Series 7™** seating with bold **Caravaggio™** pendants add pops of colour in the otherwise industrial space.



PRODUCTS

CHAIRS

SERIES 7™

Design: Arne Jacobsen, 1955

The Series 7™ chair is an icon in modern furniture history, designed by Arne Jacobsen in 1955. Its unique shape is timeless and incredibly versatile, displaying character without overpowering the eye. The chair is made from 9 layers of pressure moulded veneer for strength, flexibility and durability despite its slender form. This is the most popular design within Fritz Hansen's chair collection.

Shell: Coloured ash, lacquered and natural veneer or front- and fully upholstered in a wide range of textiles and leather types.

Base: Chromed or powder coated steel.

Accessories: Felt glides, Seat cushion, Linking device etc.



Model: 3107
 Height: 82 cm / 32.2 in
 Seat height: 46 cm / 18.1 in
 Width: 50 cm / 20 in
 Depth: 52 cm / 20.5 in
 Features: Stackable

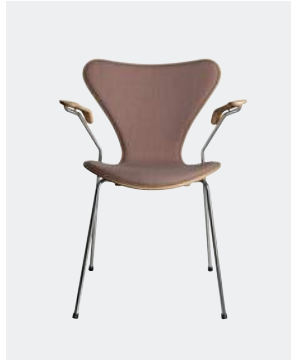

Model: 3207
 Height: 80 cm / 30.9 in
 Seat height: 46 cm / 18.1 in
 Armrest height: 69.5 cm / 27.4 in
 Width: 61 cm / 24 in
 Depth: 52 cm / 20.5 in



Model: 3117
 Height: 78-90 cm / 30.7-35.4 in
 Seat height: 44-56 cm / 17.3-22 in
 Width: 50 cm / 20 in
 Depth: 52 cm / 20.5 in



Model: 3217
 Height: 78-90 cm / 30.7-35.4 in
 Seat height: 44-56 cm / 17.3-22 in
 Armrest height: 66-78 cm / 26.4-31.1 in
 Width: 61 cm / 24 in
 Depth: 52 cm / 20.5 in



Model: 3187
 Height: 98 cm / 38.6 in
 Seat height: 64 cm / 25.2 in
 Width: 52 cm / 20.5 in
 Depth: 54 cm / 21.3 in

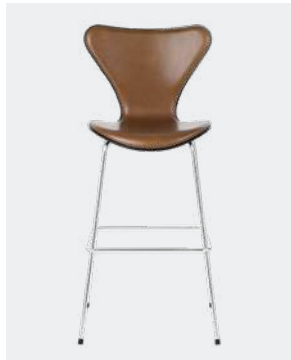

Model: 3197
 Height: 110 cm / 43.3 in
 Seat height: 76 cm / 29.9 in
 Width: 53 cm / 20.9 in
 Depth: 59 cm / 23.2 in



Model: Children's Chair
 Height: 60 cm / 23.6 in
 Seat height: 34 cm / 13.3 in
 Width: 40 cm / 15.7 in
 Depth: 42 cm / 16.5 in
 Note: Accessories assortment



Model: Junior
 Height: 79 cm / 31.1 in
 Seat height: 52 cm / 20.4 in
 Width: 42 cm / 16.5 in
 Depth: 44 cm / 17.3 in
 Note: Accessories assortment



CHAIRS

ANT™

Design: Arne Jacobsen, 1952

The Ant™ chair's visual expression is delicate and artful, much like the curves of a musical instrument. Designed by Arne Jacobsen in 1952, the chair is made from nine layers of pressure moulded veneer. Its elegant shape disguises its remarkable strength and comfort.

Shell: Coloured ash, lacquered, natural veneer.

Base: Chromed or powder coated steel.

Accessories: Felt glides, Linking device etc.

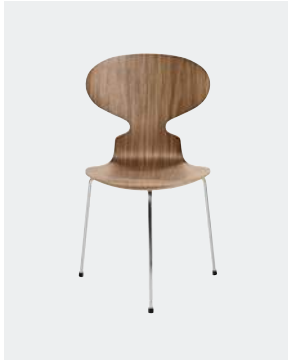

Model: 3100
Height: 77 cm / 30.3 in
Seat height: 44 cm / 17.3 in
Width: 52 cm / 20.4 in
Depth: 51 cm / 20 in
Features: Stackable



Model: 3101
Height: 81 cm / 31.9 in
Seat height: 46 cm / 18.1 in
Width: 52 cm / 20.4 in
Depth: 48 cm / 18.9 in
Features: Stackable

GRAND PRIX™

Design: Arne Jacobsen, 1957

The Grand Prix™ chair is a chair with graphic edge. It was introduced at the Designers' Spring Exhibition at the Danish Museum of Art & Design in 1957. Later that year, the chair was displayed at the Triennale in Milan where it received the Grand Prix, the finest distinction of the exhibition. The celebrated chair comes in both a steel or wood base and can be customised through a series of colours, wood types and upholstery.

Shell: Coloured ash, lacquered (3130 model only) and natural veneer (oak and walnut) or front- and fully upholstered in textile and leather.

Base: Chromed and powder coated steel or wooden legs.

Accessories: Felt glides, Linking device etc.

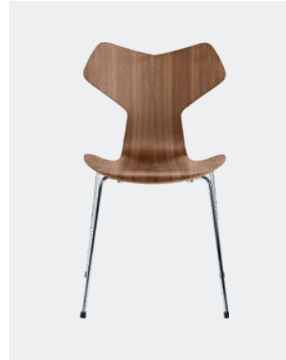

Model: 3130
Height: 83 cm / 32.7 in
Seat height: 46 cm / 18.1 in
Width: 48 cm / 18.9 in
Depth: 51 cm / 20.1 in
Features: Stackable



Model: 4130
Height: 83 cm / 32.7 in
Seat height: 46 cm / 18.1 in
Width: 50 cm / 19.7 in
Depth: 51 cm / 20.1 in

LILY™

Design: Arne Jacobsen, 1970

Arne Jacobsen first created the sleek, curvaceous Lily™ chair for Danmarks Nationalbank. Its characteristic wide shoulders and slim waist are striking examples of Jacobsen exploring and challenging the possibilities of veneer to create perfect curves and offer ultimate comfort.

Shell: Natural veneer (walnut) or fully upholstered in textile and leather.

Base: Chromed steel.

Accessories: Felt glides.

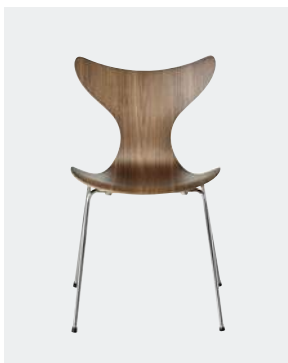

Model: 3108
Height: 83 cm / 32.6 in
Seat height: 46 cm / 18.1 in
Width: 54 cm / 21.2 in
Depth: 49 cm / 19.2 in
Features: Stackable



Model: 3208
Height: 83 cm / 32.6 in
Seat height: 46 cm / 18.1 in
Armrest height: 71 cm / 28 in
Width: 62 cm / 24.4 in
Depth: 49 cm / 19.2 in

DROP™

Design: Arne Jacobsen, 1958

The Drop™ chair draws inspiration from the feeling of an embrace, but it has also been designed for freedom of movement; creating a unique sense of comfort. Designed by Arne Jacobsen, it was originally created for the SAS Royal Hotel in Copenhagen before being relaunched in 2014. It is said to be Jacobsen's favourite chair among his many designs.

Shell: Plastic or fully upholstered in textile and leather.

Base: Chromed and powder coated steel.

Accessories: Seat cushion, Felt glides.



Model: 3110
Height: 88.5 cm / 34.8 in
Seat height: 46 cm / 18.1 in
Width: 45.5 cm / 17.9 in
Depth: 54.5 cm / 21.5 in



Model: 3110UB
Height: 88.5 cm / 34.8 in
Seat height: 46 cm / 18.1 in
Width: 45.5 cm / 17.9 in
Depth: 54.5 cm / 21.5 in

Available in additional heights

CHAIRS

CHINA CHAIR™

Design: Hans J. Wegner, 1944

The China Chair™ was designed by Hans J. Wegner in 1944. Inspired by the timeless aesthetic of ancient Chinese design in the 17th and 18th century, the China Chair epitomises his lifelong quest to understand the nature of wood and explore its possibilities. In his modern interpretation, he unfolds his talent as a wood craftsman and his flair for expressive and sculptural functionalism.

Shell/Base: Solid wood (cherry and black coloured ash).
Seat cushion: Upholstered in selected leather types.



Model: 4283
Height: 82 cm / 32.3 in
Seat height: 45 cm / 17.7 in
Armrest height: 68 cm / 26.8 in
Width: 55 cm / 21.7 in
Depth: 55 cm / 21.7 in

N01™

Design: nendo, 2018

The N01™ chair fuses Danish and Japanese design in nine layers of pressure moulded veneer and solid wood legs. Millimetre by millimetre, the design is an illustration of beauty and functionality.

Shell/Base: Mix of solid wood and veneer (beech, oak or black coloured oak).
Accessories: Seat cushion.



Model: N01
Height: 77 cm / 30.3 in
Seat height: 46.5 cm / 18.3 in
Armrest height: 66 cm / 26 in
Width: 62 cm / 24.4 in
Depth: 49 cm / 19.3 in



CHAIRS

N02™ RECYCLE

Design: nendo, 2019

The N02™ Recycle is a multi-use chair made from upcycled plastic household waste that can be recycled again. A crease in the chair's back is inspired by a folded piece of paper on the designer's studio table and provides extra support for the upper and lower back. Seven colour options are inspired by Scandinavian nature and, along with multiple base options, make N02 Recycle particularly applicable for work, meeting and dining arrangements.

Shell: Recycled plastic.

Base: Chromed or powder coated steel.

Accessories: Seat cushion, Felt glides, Linking device etc.

The EU Ecolabel is a label of environmental excellence that is awarded to products and services meeting high environmental standards throughout their life-cycle: from raw material extraction, to production, distribution and disposal.



Model: N02-10
Height: 81 cm / 31.9 in
Seat height: 46 cm / 18.1 in
Width: 54 cm / 21.3 in
Depth: 54 cm / 21.3 in
Features: Stackable

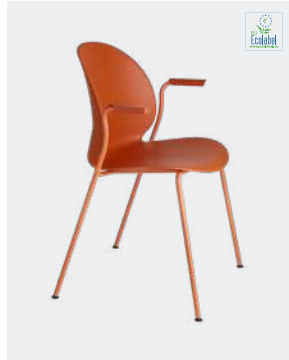

Model: N02-11
Height: 81 cm / 31.9 in
Seat height: 46 cm / 18.1 in
Armrest height: 67 cm / 26.4 in
Width: 61 cm / 24 in
Depth: 54 cm / 21.3 in
Features: Stackable



Model: N02-20
Height: 81 cm / 31.9 in
Seat height: 46 cm / 18.1 in
Width: 54 cm / 21.3 in
Depth: 53 cm / 20.9 in
Features: Stackable



Model: N02-21
Height: 81 cm / 31.9 in
Seat height: 46 cm / 18.1 in
Width: 54 cm / 21.3 in
Depth: 53 cm / 20.9 in
Features: Stackable



Model: N02-30
Height: 77-90 cm / 30.3-35.4 in
Seat height: 42-55 cm / 16.5-21.6 in
Width: 62.5 cm / 24.6 in
Depth: 62.5 cm / 24.6 in



Model: N02-31
Height: 77-90 cm / 30.3-35.4 in
Seat height: 42-55 cm / 16.5-21.6 in
Armrest height: 63-76 cm / 24.8-30 in
Width: 62.5 cm / 24.6 in
Depth: 62.5 cm / 24.6 in



Model: N02-40
Height: 99.3 cm / 39.09 in
Seat height: 64 cm / 25.2 in
Width: 51.2 cm / 21.3 in
Depth: 51.8 cm / 20.39 in

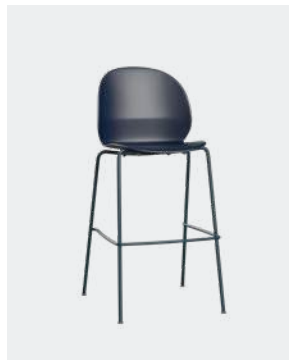

Model: N02-50
Height: 111.2 cm / 43.78 in
Seat height: 76 cm / 29.9 in
Width: 52.3 cm / 21.81 in
Depth: 56.5 cm / 22.24 in



CHAIRS

VICO DUO

Design: Vico Magistretti, 1997/2020

The Vico Duo is a stylish veneer stacking chair with simple, tight lines. Magistretti designed the original in 1997, sitting among his sketches in Fritz Hansen's design department. The chair is well suited for agile work spaces and hospitality.

Shell: Veneer (oak, walnut or black coloured ash). Available with front- and fully upholstered in a wide range of textiles and leather types.
 Base: Chromed and powder coated steel (black).
 Accessories: Seat cushion, Felt glides and transport dolly etc.



Model: VM110
 Height: 79 cm / 31.1 in
 Seat height: 46 cm / 18.1 in
 Width: 55 cm / 21.7 in
 Depth: 52 cm / 20.5 in
 Features: Stackable



Model: VM111
 Height: 79 cm / 31.1 in
 Seat height: 46 cm / 18.1 in
 Armrest height: 68 cm / 26.8 in
 Width: 60 cm / 23.6 in
 Depth: 52 cm / 20.5 in
 Features: Stackable



Model: VM112
 Height: 79.2 cm / 31.1 in
 Seat height: 46/18.1 in
 Width: 55 cm / 21.6 in
 Depth: 52 cm / 20.5 in
 Features: Stackable, linking device



Model: VM113
 Height: 79.2 cm / 31.18 in
 Seat height: 46 / 18.1 in
 Width: 60.4 cm / 23.78 in
 Depth: 51.8 cm / 20.39 in
 Features: Stackable, linking device



Model: VM114
 Height: 79.4 cm / 31.26 in
 Seat height: 46 cm / 18.1 in
 Width: 52.6 cm / 20.71 in
 Depth: 51.4 cm / 20.24 in
 Features: Stackable

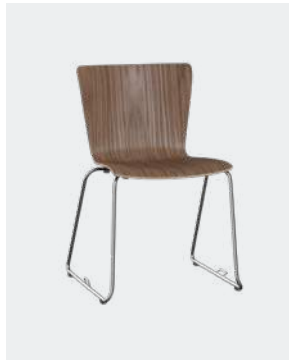

Model: VM115
 Height: 79.4 cm / 31.26 in
 Seat height: 46 cm / 18.1 in
 Width: 52.6 cm / 20.71 in
 Depth: 51.4 cm / 20.24 in
 Features: Stackable, linking device



Model: VM116
 Height: 97.6 cm / 38.43 in
 Seat height: 64 cm / 25 in
 Width: 54.9 cm / 21.61 in
 Depth: 51.4 cm / 20.24 in
 Features: Stackable



Model: VM118
 Height: 109.8 cm / 43.23 in
 Seat height: 76 cm / 30 in
 Width: 55.9 cm / 22.01 in
 Depth: 54.4 cm / 21.42 in
 Features: Stackable



CHAIRS

NAP™

Design: Kasper Salto, 2010

The iconic NAP™ chair features an elegant, curvaceous form. The contours of the Nylon shell adapt naturally to the shape of the human body and the textured waves make hours of sitting a superb experience – no matter the position. It features a high gloss back and a rippled matt front to emphasise the chair's dynamic design.

Shell: Plastic.

Base: Chromed, powder coated steel or veneer (oak).

Accessories: Seat cushion, Linking device.



Model: KS50
Height: 77 cm / 30.3 in
Seat height: 45 cm / 17.7 in
Width: 54 cm / 21.3 in
Depth: 51 cm / 20 in
Features: Stackable



Model: KS60
Height: 77 cm / 30.3 in
Seat height: 45 cm / 17.7 in
Armrest height: 64-67 cm / 25.2-26.4 in
Width: 62 cm / 24.4 in
Depth: 51 cm / 20 in
Features: Stackable



Model: KS58
Height: 97 cm / 38.2 in
Seat height: 64 cm / 25.2 in
Width: 56 cm / 22 in
Depth: 52 cm / 20.5 in



Model: KS68
Height: 97 cm / 38.2 in
Seat height: 64 cm / 25.2 in
Armrest height: 83-86 cm / 32.7-33.9 in
Width: 62 cm / 24.4 in
Depth: 52 cm / 20.5 in

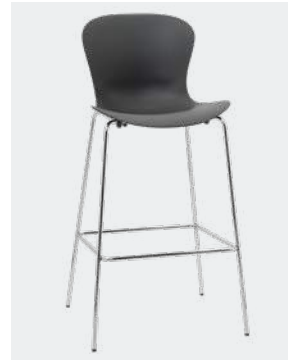

Model: KS59
Height: 109 cm / 43 in
Seat height: 76 cm / 30 in
Width: 56 cm / 22 in
Depth: 54 cm / 21.2 in



Model: KS69
Height: 109 cm / 43 in
Seat height: 76 cm / 30 in
Armrest height: 95-98 cm / 37.4-38.6 in
Width: 62 cm / 24.4 in
Depth: 54 cm / 21.2 in



Model: KS52
Height: 77 cm / 30.3 in
Seat height: 45 cm / 17.7 in
Width: 54 cm / 21.3 in
Depth: 51 cm / 20 in



Model: KS62
Height: 77 cm / 30.3 in
Seat height: 45 cm / 17.7 in
Armrest height: 64-67 cm / 25.2-26.4 in
Width: 62 cm / 24.4 in
Depth: 51 cm / 20 in

Available in additional height (chromed steel)

CHAIRS

OXFORD™

Design: Arne Jacobsen, 1965

The Oxford™ chair was handcrafted for the professors at St Catherine's College in Oxford and designed by Arne Jacobsen. A symbol of prestige and status, the high back and smooth, curved veneer form were crafted to invoke a sense of space and privacy. The design evolved over time into today's Oxford™.

Shell: Fully upholstered in textile or leather.
 Base: Satin polished aluminum, chrome (five-star base only) and powder-coated steel/aluminium.
 Options: Automatic return and armpads etc.



Model: 3141T
 Height: 89 cm / 35 in
 Seat height: 46 cm / 18.1 in
 Width: 50 cm / 19.6 in
 Depth: 61 cm / 24 in



Model: 3171T
 Height: 89 cm / 35 in
 Seat height: 46 cm / 18.1 in
 Width: 62 cm / 24.4 in
 Depth: 61 cm / 24 in



Model: 3191T
 Height: 82-96 cm / 32.2-37.7 in
 Seat height: 37-51 cm / 14.5-20 in
 Width: 62 cm / 24.4 in
 Depth: 58 cm / 22.8 in



Model: 3171W
 Height: 89 cm / 35 in
 Seat height: 46 cm / 18.1 in
 Width: 62 cm / 24.4 in
 Depth: 61 cm / 24 in



Model: 3191W
 Height: 87-101 cm / 34.2 - 39.7 in
 Seat height: 42-56 cm / 16.5-20 in
 Width: 62 cm / 24.4 in
 Depth: 58 cm / 22.8 in



Model: 3241T
 Height: 89 cm / 35 in
 Seat height: 46 cm / 18.1 in
 Armrest height: 68 cm / 26.7 in
 Width: 62 cm / 24.4 in
 Depth: 61 cm / 24 in



Model: 3271T
 Height: 89 cm / 35 in
 Seat height: 46 cm / 18.1 in
 Armrest height: 68 cm / 26.7 in
 Width: 62 cm / 24.4 in
 Depth: 61 cm / 24 in



Model: 3291T
 Height: 82-96 cm / 32.2-37.7 in
 Seat height: 37-51 cm / 14.5-20 in
 Armrest height: 59-73 cm / 23.2-28.7 in
 Width: 62 cm / 24.4 in
 Depth: 58 cm / 22.8 in



Model: 3271W
 Height: 89 cm / 35 in
 Seat height: 46 cm / 18.1 in
 Armrest height: 68 cm / 26.7 in
 Width: 62 cm / 24.4 in
 Depth: 61 cm / 24 in



Model: 3291W
 Height: 87-101 cm / 34.2-30.7 in
 Seat height: 42-56 cm / 16.5-20 in
 Armrest height: 64-78 cm / 25.1-30.7 in
 Width: 62 cm / 24.4 in
 Depth: 58 cm / 22.8 in



Model: 3143T
 Height: 102 cm / 40.1 in
 Seat height: 46 cm / 18.1 in
 Width: 50 cm / 19.6 in
 Depth: 63 cm / 24.8 in



Model: 3173T
 Height: 102 cm / 40.1 in
 Seat height: 46 cm / 18.1 in
 Width: 62 cm / 24.4 in
 Depth: 63 cm / 24.8 in

CHAIRS



Model: 3193T
 Height: 95-109 cm / 37.4-42.9 in
 Seat height: 37-51 cm / 14.5-20 in
 Width: 62 cm / 24.4 in
 Depth: 60 cm / 23.6 in



Model: 3173W
 Height: 102 cm / 40.1 in
 Seat height: 46 cm / 18.1 in
 Width: 62 cm / 24.4 in
 Depth: 63 cm / 24.8 in



Model: 3193W
 Height: 100-114 cm / 39.3-44.8 in
 Seat height: 42-56 cm / 16.5-22 in
 Width: 62 cm / 24.4 in
 Depth: 60 cm / 23.6 in



Model: 3243T
 Height: 102 cm / 40.1 in
 Seat height: 46 cm / 18.1 in
 Armrest height: 68 cm / 26.7 in
 Width: 62 cm / 24.4 in
 Depth: 63 cm / 24.8 in



Model: 3273T
 Height: 102 cm / 40.1 in
 Seat height: 46 cm / 18.1 in
 Armrest height: 68 cm / 26.7 in
 Width: 62 cm / 24.4 in
 Depth: 63 cm / 24.8 in



Model: 3293T
 Height: 95-109 cm / 37.4-42.9 in
 Seat height: 37-51 cm / 14.5-20 in
 Armrest height: 59-73 cm / 23.2-28.7 in
 Width: 62 cm / 24.4 in
 Depth: 60 cm / 23.5 in



Model: 3273W
 Height: 102 cm / 40.1 in
 Seat height: 46 cm / 18.1 in
 Armrest height: 68 cm / 26.7 in
 Width: 62 cm / 24.4 in
 Depth: 63 cm / 24.8 in

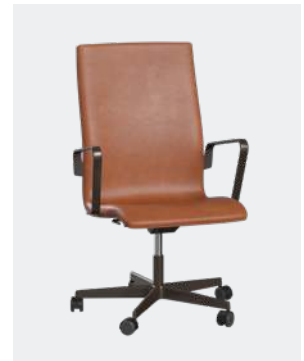

Model: 3293W
 Height: 100-114 cm / 39.3-44.8 in
 Seat height: 42-56 cm / 16.5-22 in
 Armrest height: 64-78 cm / 25.1-30.7 in
 Width: 62 cm / 24.4 in
 Depth: 60 cm / 23.6 in

LITTLE GIRAFFE™

Design: Arne Jacobsen, 1959

The Giraffe chair was designed by Arne Jacobsen in 1959, specifically for the restaurant at the SAS Royal Hotel in Copenhagen. Its high back and padded armrests make for a cosy and comfortable seat. The Little Giraffe™ chair is an evolution of its iconic predecessor – a striking rendition suitable for hospitality, meeting rooms or dining spaces.

Shell: Fully upholstered in textile or leather (fixed or replaceable cover).
Base: Chromed or powder coated steel (select models) and polished or black powder coated aluminium (select models).

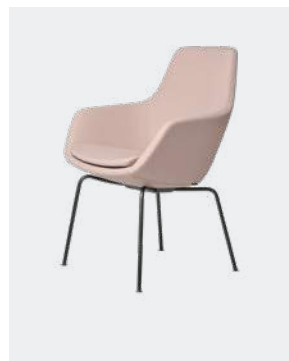

Model: 3201 / 3201R
 Height: 89.4 cm / 35.2 in
 Seat height: 46 cm / 18.1 in
 Armrest height: 65.5 cm / 25.7 in
 Width: 64 cm / 25.1 in
 Depth: 61 cm / 24 in



Model: 3211 / 3211R
 Height: 85-96 cm / 33.4-37.7 in
 Seat height: 43-54 cm / 16.9-21.2 in
 Armrest height: 62.5-73.5 cm / 24.6-28.9 in
 Width: 64 cm / 25.1 in
 Depth: 61 cm / 24 in

CHAIRS

PK8™

Design: Poul Kjærholm, 1978/2007

For many years, the PK8™ existed only as a prototype in the home of Hanne Kjærholm, the wife of Poul Kjærholm. Today, it's widely recognised as a striking execution of Scandinavian craftsmanship. Its unique three-legged form and sinuous curves give it an expression all its own.

Shell: Plastic (black or white) with front upholstery in leather.
Base: Anodised satin brushed aluminium.



Model: PK8
Height: 77 cm / 30.3 in
Seat height: 44 cm / 17.3 in
Width: 59 cm / 23.2 in
Depth: 51 cm / 20 in

PK9™

Design: Poul Kjærholm, 1960

The PK9's unique shape is characterised by three pieces of satin-brushed stainless spring steel that act as a column, carrying the leather seating element. Poul Kjærholm was inspired by a sand imprint of his wife's behind from a day at the beach. Later, during the design process, Hanne Kjærholm sat in boxes of clay to find the most optimal and comfortable solution.

Shell: Fully upholstered in leather.
Base: Satin brushed stainless spring steel.



Model: PK9
Height: 77 cm / 30.3 in
Seat height: 43 cm / 16.9 in
Width: 58 cm / 22.8 in
Depth: 58 cm / 22.8 in

PK11™

Design: Poul Kjærholm, 1957

Characterised by its three-legged satin brushed stainless steel frame, PK11™ strikes the perfect balance of curves and bold angles. Designed by Poul Kjærholm in 1957, it is a complex yet elegant chair, created as a companion to the PK51™ worktable.

Shell: Armrest in veneer (ash) with a seat upholstered in leather.
Base: Satin brushed stainless steel.



Model: PK11
Height: 69 cm / 27.2 in
Seat height: 43-44 cm / 17-17.3 in
Width: 64 cm / 25.2 in
Depth: 44 cm / 17.3 in



STOOLS

PK33™

Design: Poul Kjærholm, 1959

The iconic PK33™ epitomises Poul Kjærholm's use of assembly techniques, his exploration of materials and his simplification of structure into a type-form. The three-legged matt chromed spring steel stool borrows elements from his other designs, while still maintaining its own unique expression.

Seat: Canvas or leather.
Base: Matt chromed spring steel.



Model: PK33
Height: 34 cm / 13.4 in
Width: 53 cm / 20.9 in
Depth: 53 cm / 20.9 in

PK91™

Design: Poul Kjærholm, 1961

The PK91™, designed by Poul Kjærholm, is an homage to the designer's mentor, Kaare Klint, who made a folding chair in wood in 1930. This folding stool is unmistakably a Kjærholm classic.

Seat: Canvas or leather.
Base: Satin brushed stainless steel.



Model: PK91
Height: 41 cm / 16.1 in
Width: 59 cm / 23.2 in
Depth: 45 cm / 17.7 in

DOT™

Design: Arne Jacobsen, 1955

The Dot™ stool is beautiful, simple seating that can be used as core or extra seating in the office, or at home. Modern, minimal and quiet, this sophisticated design was used by Arne Jacobsen in multiple, important projects.

Seat: Leather (Wild in walnut / Intense in black / Buffed in Lava).
Base: Chromed or powder coated (matt black) steel.



Model: 840100 / 840105
Height: 46 cm / 18.1 in
Width: 34 cm / 13.4 in
Depth: 34 cm / 13.4 in
Note: Accessories assortment

HIGH DOT™

Design: Arne Jacobsen, 1955

The High Dot™ stool is beautiful, simple high seating for counters, bars or high office tables. Modern, minimal and quiet, this sophisticated design by Arne Jacobsen is timeless and practical.

Seat: Leather (Wild in walnut / Intense in black / Buffed in Lava).
Base: Chromed or powder coated (matt black) steel.



Model: 840106 / 840107
Height: 65 cm / 25.6 in
Width: 44 cm / 17.3 in
Depth: 44 cm / 17.3 in
Note: Accessories assortment

LOUNGE

SERIES 3300™

Design: Arne Jacobsen, 1956

The Series 3300™ was designed by Arne Jacobsen for the SAS Air Terminal connected to the SAS Royal Hotel. The series exudes Jacobsen's unfailing sense of line and proportion and is proof of his ability to design everlasting classics. The Series 3300™ forms an elegant contrast to the organic shapes of the Egg and Swan chairs, also designed especially for the Royal Hotel.

Shell: Fully upholstered in textile or leather.
Base: Chromed steel.



Model: 3300
Height: 72 cm / 28.4 in
Seat height: 36 cm / 14.2 in
Armrest height: 49-54 cm / 19.3-21.3 in
Width: 73 cm / 28.7 in
Depth: 79 cm / 31.1 in
Features: 2- and 3-seater sofa

SWAN™

Design: Arne Jacobsen, 1958

The beautiful Swan™ chair was designed by Arne Jacobsen in 1958 for the lobby and lounge areas of the SAS Royal Hotel in Copenhagen. The design contains no straight lines, making it look organic and soft despite its simplicity and strong architectural appeal.

Shell: Fully upholstered in textile or leather.
Base: Aluminium/Satin polished steel/Powder coated steel.



Model: 3320
Height: 77 cm / 30.3 in
Seat height: 40 cm / 15.8 in
Armrest height: 58 cm / 22.8 in
Width: 74 cm / 33.9 in
Depth: 68 cm / 26.8 in
Features: Automatic return, 2-seater sofa

POT™

Design: Arne Jacobsen, 1959

Arne Jacobsen created the Pot™ in 1959 for the SAS Royal Hotel in Copenhagen. Years later, the Pot was relaunched with a fresh take on Jacobsen's signature lounge chair, revitalised for the modern interior. Retaining the striking shape of its predecessor, the modern rendition meets today's demands through improved comfort and quality.

Shell: Fully upholstered in textile or leather.
Base: Chromed or dark brown powder coated steel.



Model: 3318
Height: 70 cm / 27.5 in
Seat height: 42.7 cm / 16.8 in
Width: 75.5 cm / 29.7 in
Depth: 60 cm / 23.6 in



LOUNGE

EGG™

Design: Arne Jacobsen, 1958

The Egg™ chair by Arne Jacobsen is an everlasting Danish design masterpiece. Like a sculptor, Jacobsen strived to shape the shell's perfect form by experimenting with wire and plaster in his garage. Today, it is recognised worldwide as one of the triumphs of Jacobsen's legendary career and a monumental achievement in Scandinavian craftsmanship.

Shell: Fully upholstered in textile or leather.

Base: Aluminium/Satin polished steel/Powder coated steel.



Model: 3316
Height: 107 cm / 42.1 in
Seat height: 37 cm / 14.6 in
Armrest height: 58 cm / 22.8 in
Width: 86 cm / 33.9 in
Depth: 79-95 cm / 31.1-37.4 in
Features: Automatic return

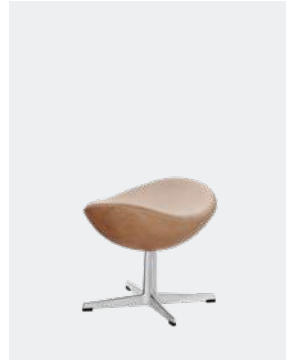

Model: 3127
Height: 37 cm / 14.6 in
Width: 56 cm / 22 in
Depth: 40 cm / 15.7 in

OKSEN™

Design: Arne Jacobsen, 1966

The Oksen easy chair takes on a sharp, powerful expression, dominating a room like nothing else. Arne Jacobsen shocked design connoisseurs all over the world when he first introduced Oksen™ in 1966 – after no less than five years of design experimentation. In contrast to many of his earlier pieces characterised by rounded, organic shapes, Oksen is the largest and most controversial chair Arne Jacobsen ever designed.

Shell: Fully upholstered in leather.

Base: Satin polished or black powder coated aluminium.



Model: 4201
Height: 115 cm / 45.2 in
Seat height: 43 cm / 17 in
Armrest height: 58 cm / 22.8 in
Width: 101 cm / 39.8 in
Depth: 87 cm / 34.3 in
Features: Automatic return

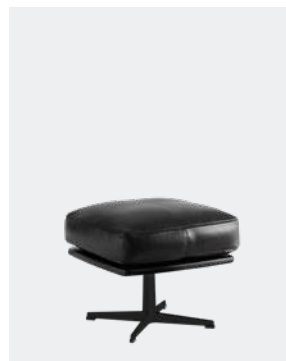

Model: 4210
Height: 40 cm / 15.7 in
Width: 52 cm / 20.4 in
Depth: 52 cm / 20.4 in

LOUNGE

RO™

Design: Jaime Hayon, 2013

The Ro™ lounge chair is aptly named after the Danish word for 'tranquillity'. Designed by Jaime Hayon, the easy chair creates space for relaxation and reflection, enticing you to immerse in its curves and take a moment for yourself. The four-legged base is made of brushed aluminium or solid oak with a clear lacquer finish.

Shell: Fully upholstered in textile (mix two textiles for shell and cushions) or leather.

Base: Brushed aluminium or solid wood (oak).



Model: JH1
 Height: 113 cm / 44.5 in
 Seat height: 43 cm / 17 in
 Armrest height: 61 cm / 24 in
 Width: 80 cm / 31.5 in
 Depth: 97 cm / 38.2 in
 Features: 2-seater sofa



Model: JH2
 Height: 113 cm / 44.5 in
 Seat height: 43 cm / 17 in
 Armrest height: 61 cm / 24 in
 Width: 80 cm / 31.5 in
 Depth: 97 cm / 38.2 in
 Features: 2-seater sofa



Model: JH11
 Height: 40 cm / 15.7 in
 Width: 58 cm / 22.8 in
 Depth: 49 cm / 19.3 in



Model: JH12
 Height: 40 cm / 15.7 in
 Width: 58 cm / 22.8 in
 Depth: 49 cm / 19.3 in

FRI™

Design: Jaime Hayon, 2015

The Fri™ easy chair adds a striking, sophisticated expression to any interior. Designed by Spanish designer Jaime Hayon, the chair has a soft, sculptured form that is as pleasing to the body as it is to the eye.

Shell: Fully upholstered in textile or leather.

Base: Brushed aluminium or solid wood (oak).



Model: JH4
 Height: 90.5 cm / 35.6 in
 Seat height: 43 cm / 17 in
 Armrest height: 58.5 cm / 23 in
 Width: 80 cm / 31.5 in
 Depth: 88 cm / 34.6 in
 Features: Non-glued upholstery



Model: JH5
 Height: 90.5 cm / 35.6 in
 Seat height: 43 cm / 17 in
 Armrest height: 58.5 cm / 23 in
 Width: 80 cm / 31.5 in
 Depth: 88 cm / 34.6 in
 Features: Non-glued upholstery



Model: JH14
 Height: 40 cm / 15.7 in
 Width: 58 cm / 22.8 in
 Depth: 49 cm / 19.3 in



Model: JH15
 Height: 40 cm / 15.7 in
 Width: 58 cm / 22.8 in
 Depth: 49 cm / 19.3 in

LOUNGE

VIA57™

Design: Bjarke Ingels in collaboration with KiBiSi, 2016

The VIA57™ easy chair was designed as part of a collaboration between Bjarke Ingels and Danish design group KiBiSi. The collaboration celebrates the completion of Bjarke Ingels Group's first New York City project – the VIA57 WEST building – offering design aficionados around the world the opportunity to experience a piece of the Manhattan skyline in their own homes.

Shell: Fully upholstered in textile.
Base: Solid wood (oak).



Model: BI01
Height: 78 cm / 30.7 in
Seat height: 42 cm / 16.4 in
Width: 93 cm / 36.5 in
Depth: 91 cm / 35.8 in

FRED™

Design: Jaime Hayon, 2019

Elegant from every angle, the Fred™ lounge chair is a nod to calm and comfortable living. Designed by Jamie Hayon, the chair features a low, open silhouette and a sculpted wooden frame, crafted and assembled with care by hand. Wide, flat armrests and upright seating support the neck and arms – ideal for long periods of socialising or reading.

Cushions: Upholstered in textile or leather.
Base: Solid wood (black painted ash, walnut stained oak, clear lacquered oak or oiled oak).



Model: JH97
Height: 85.2 cm / 33.5 in
Seat height: 41 cm / 16.1 in
Armrest height: 55.6 cm / 21.8 in
Width: 77.4 cm / 30.4 in
Depth: 80.5 cm / 31.7 in

LET™

Design: Sebastian Herkner, 2020

The Let™ lounge chair is a low lounge chair with a fine silhouette and sculptural design by Sebastian Herkner for Fritz Hansen. The seat cushion visually 'floats' on the frame, surrounded by an enveloping backrest. Let embodies the German designer's skills and aesthetic, with Fritz Hansen's expert craftsmanship. It is designed for a wide variety of expressions and interior styles.

Shell: Fully upholstered seat and backrest.
Base: Solid wood (lacquered oak, lacquered ash or black coloured ash), chromed or powder coated steel.



Model: SH200
Height: 80 cm / 31.4 in
Seat height: 42 cm / 16.5 in
Width: 56.5 cm / 22.2 in
Depth: 50 cm / 19.7 in



Model: SH210
Height: 80 cm / 31.4 in
Seat height: 42 cm / 16.5 in
Width: 56.5 cm / 22.2 in
Depth: 50 cm / 19.7 in

LOUNGE

PK20™

Design: Poul Kjærholm, 1968

The PK20™ is a laidback and elegant easy chair, designed by Poul Kjærholm. Handcrafted in both wicker and leather, the chair features soft leather upholstery and a reclining headrest, resting on a flexible matt chromed spring steel frame. Over the years, the PK20 has become a Poul Kjærholm classic – as well as a permanent fixture at the Victoria and Albert Museum in London.

Shell: Leather (w. headrest) or wicker.
Base: Matt chromed spring steel.



Model: PK20
Height: 84 cm / 33.1 in
Seat height: 37 cm / 14.6 in
Width: 80 cm / 31.5 in
Depth: 71 cm / 28 in



Model: PK20
Height: 89 cm / 35 in
Seat height: 37 cm / 14.6 in
Width: 80 cm / 31.5 in
Depth: 71 cm / 28 in

PK22™

Design: Poul Kjærholm, 1956

The PK22™ has the subtle silhouette that has become a genuine design classic. The iconic chair exemplifies Poul Kjærholm's vision and quest for the ideal form and dimension. It remains a fundamentally modern chair for design enthusiasts today.

Shell: Canvas, leather or wicker.
Base: Satin brushed stainless spring steel.



Model: PK22
Height: 71 cm / 28 in
Seat height: 35 cm / 13.8 in
Width: 63 cm / 24.8 in
Depth: 63 cm / 24.8 in

PK25™

Design: Poul Kjærholm, 1951

The PK25™ was designed by Poul Kjærholm for his final graduation project at the School of Arts and Crafts in 1952. Also known as the 'Element' chair, the PK25 is a striking example of Kjærholm's eagerness to transform common, industrial materials into striking works of art. Kjærholm was determined to reduce the chair to a single piece of each material, resulting in its overarching hallmark: the continual steel frame that bends through the form without interruption.

Shell: Flag halyard (natural or black)
Base: Matt chromed spring steel.



Model: PK25
Height: 75 cm / 29.5 in
Seat height: 40 cm / 15.7 in
Width: 69 cm / 27.2 in
Depth: 73 cm / 28.7 in

LOUNGE

PK24™

Design: Poul Kjærholm, 1965

The PK24™ chaise longue chair stands out as perhaps the most recognisable chair in Fritz Hansen's Poul Kjærholm's collection. Inspired by the Rococo period and the French chaise longue, Kjærholm used steel to support a curvy, flowing form. He labelled it the 'Hammock Chair' to stress that it functions by suspending the body between two points.

Shell: Leather or wicker.

Base: Satin brushed stainless steel.



Model: PK24
Height: 85 cm / 34.3 in
Seat height: 14 cm / 5.5 in
Width: 67 cm / 26.4 in
Depth: 155 cm / 61 in
Features: Leather upholstered headrest

PK31™

Design: Poul Kjærholm, 1958

The PK31™ chair and sofa series is a prime example of Poul Kjærholm's ability to work with exquisite materials and minimalism. In the search for the ideal form, Kjærholm created the PK31 – a fusion of elegance, luxury and comfort. The PK31 series is available as an armchair and a 2- or 3-seater sofa and features a matt chromed spring steel frame.

Shell: Fully upholstered in leather.

Base: Matt chromed spring steel.



Model: PK31
Height: 76 cm / 29.9 in
Seat height: 38 cm / 15 in
Armrest height: 48 cm / 18.9 in
Width: 76 cm / 29.9 in
Depth: 76 cm / 29.9 in
Features: 2- and 3-seater sofa

PK80™

Design: Poul Kjærholm, 1957

The PK80™ Daybed is the embodiment of Poul Kjærholm's talent for refining historical models and distilling design down to its very essence. The daybed draws inspiration from a couch designed by Mies van der Rohe and Lilly Reich in 1930. It can be found today in the Museum of Modern Art and around the world as a celebrated illustration of craftsmanship and modern design.

Shell: Canvas or leather.

Base: Satin brushed stainless steel.



Model: PK80
Height: 30 cm / 11.8 in
Width: 190 cm / 74.8 in
Depth: 80 cm / 31.5 in

PK81™

Design: Poul Kjærholm, 1959

PK81™ is a square version of Poul Kjærholm's classic daybed, made to furnish the public area of the new Tårnby town hall by Halldor Gunløgsson and Jørn Nielsen. Today, it graces powerful spaces around the world, including the Museum of Modern Art in New York City.

Shell: Leather.

Base: Satin brushed stainless steel.



Model: PK81
Height: 30 cm / 11.8 in
Width: 140 cm / 55.1 in
Depth: 140 cm / 55.1 in

SOFAS

SWAN SOFA™

Design: Arne Jacobsen, 1958

The Swan Sofa™ was designed by Arne Jacobsen in 1958 for the SAS Royal Hotel in Copenhagen and reintroduced to Fritz Hansen's collection in 2000. The design contains no straight lines, making it organic and soft to the eye despite its simplicity and strong architectural appeal.

Shell: Fully upholstered in textile or leather.
Base: Satin polished aluminium.



Model: 3321
Height: 79 cm / 31.1 in
Seat height: 40 cm / 15.8 in
Armrest height: 58 cm / 22.8 in
Width: 144 cm / 56.7 in
Depth: 74 cm / 29.1 in
Features: Lounge chair

PK26™

Design: Poul Kjærholm, 1956

The PK26™ is a striking wall-mounted sofa in flat steel with leather-covered back and seat, designed by Poul Kjærholm. The sofa appears to float mid-air with an extraordinary design that is beautiful from every angle.

Shell: Fully upholstered in leather.
Base: Matt chromed spring steel.



Model: PK26
Height: 76 cm / 29.9 in
Seat height: 36 cm / 14.2 in
Width: 152 cm / 59.8 in
Depth: 76 cm / 29.9 in
Features: Extendable

PK31™

Design: Poul Kjærholm, 1958

The PK31™ chair and sofa series is a prime example of Poul Kjærholm's ability to work with exquisite materials and minimalism. In the search for the ideal form, Kjærholm created the PK31 – a fusion of elegance, luxury and comfort. The PK31 series is available as an armchair and a 2- or 3-seater sofa and features a matt chromed spring steel frame.

Shell: Fully upholstered in leather.
Base: Matt chromed spring steel.



Model: PK31/2
Height: 76 cm / 29.9 in
Seat height: 38 cm / 15 in
Armrest height: 48 cm / 18.9 in
Width: 137 cm / 54 in
Depth: 76 cm / 29.9 in
Features: Lounge chair



Model: PK31/3
Height: 76 cm / 29.9 in
Seat height: 38 cm / 15 in
Armrest height: 48 cm / 18.9 in
Width: 198 cm / 78 in
Depth: 76 cm / 29.9 in
Features: Extension units, Lounge chair

SOFAS

LISSONI SOFA™

Design: Piero Lissoni, 2006

The Lissoni Sofa™ is a sophisticated, modern sofa that adds a healthy dose of comfort and luxury to everyday life. Characterized by clean lines and flawless attention to detail, this sofa by Piero Lissoni has a remarkably pronounced appearance that elevates and adds character to any room.

Shell: Fully upholstered in textile or leather.

Base: Matt polished stainless steel/ Powder coated steel.



Model: PL112
Height: 75 cm / 29.5 in
Seat height: 41 cm / 16.1 in
Armrest height: 53 cm / 20.7 in
Width: 198 cm / 77.9 in
Depth: 92 cm / 36.2 in



Model: PL113
Height: 75 cm / 29.5 in
Seat height: 41 cm / 16.1 in
Armrest height: 53 cm / 20.7 in
Width: 288 cm / 113.4 in
Depth: 92 cm / 36.2 in



Model: PL112S
Height: 75 cm / 29.5 in
Seat height: 41 cm / 16.1 in
Armrest height: 53 cm / 20.7 in
Width: 168 cm / 66.14 in
Depth: 92 cm / 36.2 in



Model: PL113S
Height: 75 cm / 29.5 in
Seat height: 41 cm / 16.1 in
Armrest height: 53 cm / 20.7 in
Width: 243 cm / 88.2 in
Depth: 92 cm / 36.2 in

SOFAS

FAVN™

Design: Jaime Hayon, 2011

Derived from the Danish term for 'embrace', the Favn™ sofa is a design collaboration between designer Jaime Hayon and Fritz Hansen. Its open and rounded curves are intended to appeal and invite – the perfect setting for relaxation, work and everything in-between.

Shell: Fully upholstered in textile (mix three textiles for shell, cushions and decorative cushions)

Base: Brushed aluminium legs.



Model: JH3
Height: 88 cm / 34.6 in
Seat height: 42 cm / 16.5 in
Armrest height: 60 cm / 23.6 in
Width: 221 cm / 87 in
Depth: 93 cm / 36.6 in
Features: Buy additional decorative cushions

SERIES 3300™

Design: Arne Jacobsen, 1956

The Series 3300™ was designed by Arne Jacobsen for the SAS Air Terminal connected to the SAS Royal Hotel. The series exudes Jacobsen's unflinching sense of line and proportion and is proof of his ability to design everlasting classics. The Series 3300™ forms an elegant contrast to the organic shapes of the Egg and Swan chairs, also designed especially for the Royal Hotel.

Shell: Fully upholstered in textile or leather.

Base: Chromed steel.



Model: 3302
Height: 72 cm / 28.4 in
Seat height: 36 cm / 14.2 in
Armrest height: 49-54 cm / 19.3-21.3 in
Width: 126 cm / 49.6 in
Depth: 79 cm / 31.1 in
Features: Lounge chair



Model: 3303
Height: 72 cm / 28.4 in
Seat height: 36 cm / 14.2 in
Armrest height: 49-54 cm / 19.3-21.3 in
Width: 182 cm / 71.7 in
Depth: 79 cm / 31.1 in
Features: Extension units, lounge chair

SOFAS

ALPHABET SOFA™ SERIES

Design: Piero Lissoni, 2008

The Alphabet™ Sofa Series is a modular sofa system with units that can be combined in a variety of ways. The fully upholstered seat, back and armrest units come in a wide range of textiles, which can be removed for cleaning or replacement. You can choose to include a piping along the edges on both seat, back and armrests.

Shell: Fully upholstered in textile.

Accessories: Loose decorative cushions.



Model: PL240-4
 Height: 70 cm / 27.6 in
 Seat height: 40 cm / 15.7 in
 Width: 240 cm / 94.5 in
 Depth: 120 cm / 47.2 in

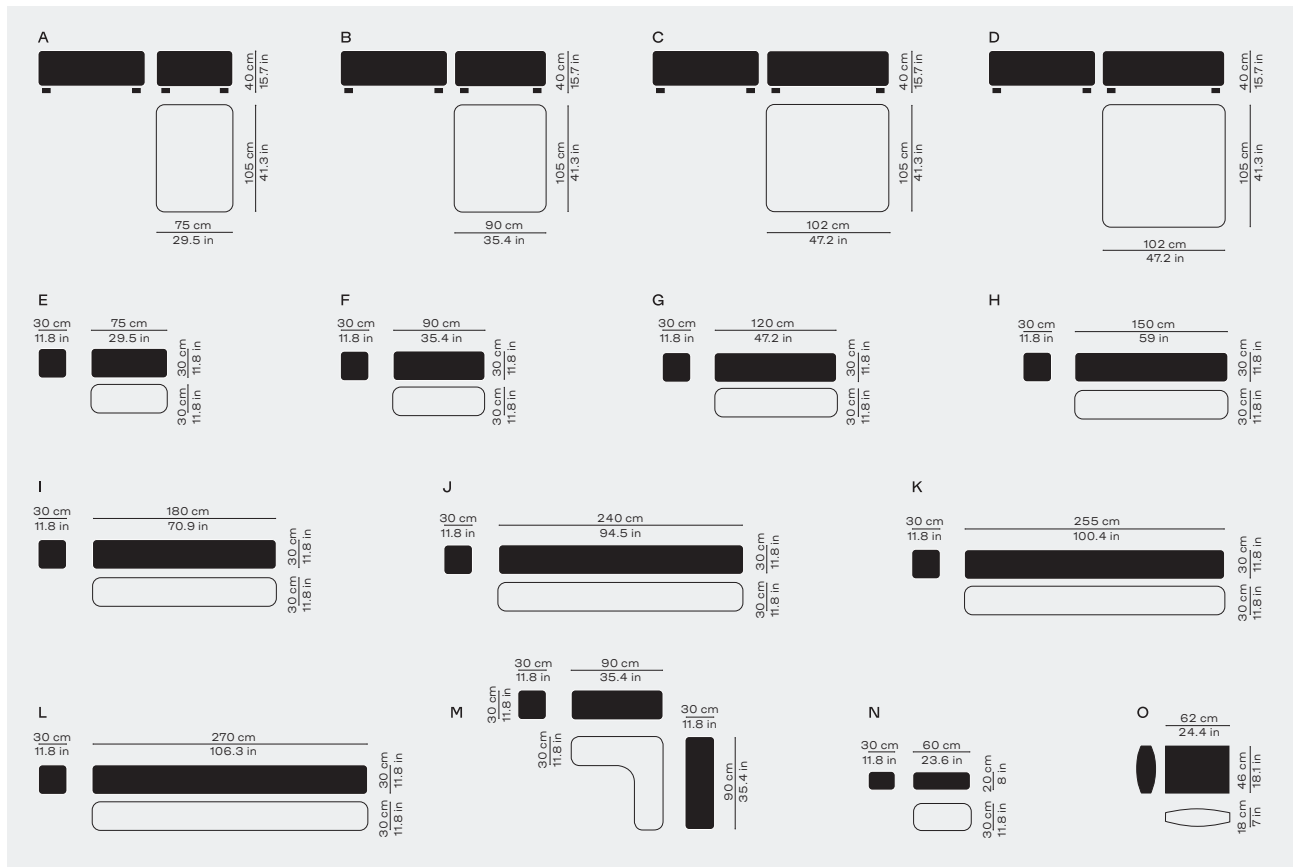

- A Seat unit
- B Seat unit
- C Seat unit
- D Seat unit
- E Back unit
- F Back unit
- G Back unit
- H Back unit
- I Back unit
- J Back unit
- K Back unit
- L Back unit
- M Back corner unit
- N Armrest unit
- O Decorative cushion

SOFAS

RO™ SOFA

Design: Jaime Hayon, 2017

The two-seater Ro sofa showcases the curvy form and playful expression that serve as the bedrock of Jaime Hayon's renowned design philosophy. Here, softness is expressed in an intimate yet spacious social setting for two.

Shell: Fully upholstered in textile (mix two textiles for shell and cushions)
Base: Brushed aluminium or solid wood (oak).



Model: JH110
 Height: 115.5 cm / 45.5 in
 Seat height: 42.5 cm / 16.7 in
 Armrest height: 62.5 cm / 24.6 in
 Width: 150 cm / 59.1 in
 Depth: 97 cm / 38.2 in
 Features: Lounge chair



Model: JH120
 Height: 115.5 cm / 45.5 in
 Seat height: 42.5 cm / 16.7 in
 Armrest height: 62.5 cm / 24.6 in
 Width: 150 cm / 59.1 in
 Depth: 97 cm / 38.2 in
 Features: Lounge chair

LUNE™

Design: Jaime Hayon, 2017

The sculptural, curvaceous Lune™ sofa is characteristic of designer Jaime Hayon and sits at the intersection of clean Nordic aesthetics and southern elegance. Lune is a functional, modular sofa that offers a myriad of possibilities: from a straight two-seater to larger L-shapes with chaise longue options. The result: a flexible sofa that is not only cosy and comfortable but also inherently beautiful from every angle.

Shell: Fully upholstered in textile or leather.
Base: Brushed aluminium, oak or black coloured oak.



Model: JH200
 Height: 81.5 cm / 32 in
 Seat height: 40.5 cm / 15.9 in
 Armrest height: 60.5 cm / 23.8 in
 Width: 155 cm / 61.1 in
 Depth: 93.5 cm / 36.8 in

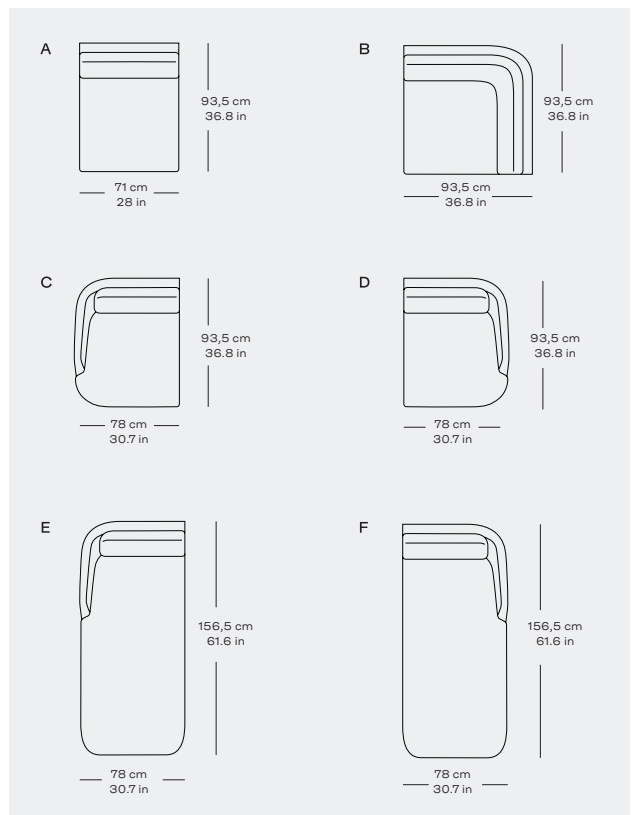

A Central unit
 B Corner unit
 C Arm unit left
 D Arm unit right
 E Chaise longue unit left
 F Chaise longue unit right

SOFAS

PLENUM™

Design: Jaime Hayon, 2018

Plenum™ pays homage to the modern workspace – the perfect setting for collaboration, concentration or relaxation. Designed by Jamie Hayon, the curved high-back sofa system consists of one, two or three-seater units and features a range of added functionalities such as power plugs, USB ports and mounted or separate tables.

Sofa shell: Fully upholstered in textile.

Table top: Light grey laminate.

Base: Black powder coated steel.



Model: JH1001
Height: 143.4 cm / 56.4 in
Seat height: 46 cm / 18.1 in
Armrest height: 69.4 cm / 27.3 in
Width: 110.5 cm / 43.5 in
Depth: 82.1 cm / 32.3 in
Features: Power unit incl. USB ports*

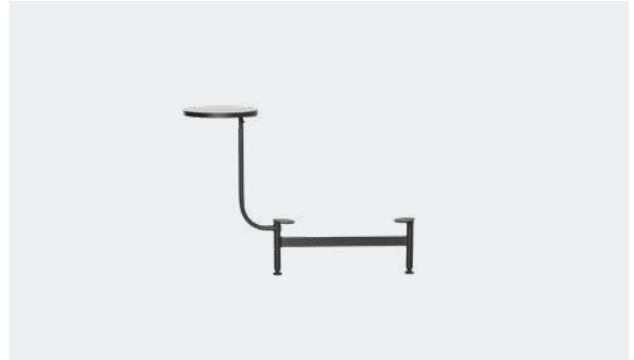

Model: JH70
Height: 68.1 cm / 26.8 in
Diameter: 30 cm / 11.8 in
Note: To be mounted on sofa units upon order



Model: JH1002
Height: 143.4 cm / 56.4 in
Seat height: 46 cm / 18.1 in
Armrest height: 69.4 cm / 27.3 in
Width: 173.5 cm / 68.3 in
Depth: 82.1 cm / 32.3 in
Features: Power unit incl. USB ports*



Model: JH75
Height: 51.7 cm / 20.3 in
Length: 126 cm / 49.6 in
Width: 75.9 cm / 29.8 in



Model: JH1003
Height: 143.4 cm / 56.4 in
Seat height: 46 cm / 18.1 in
Armrest height: 69.4 cm / 27.3 in
Width: 236.5 cm / 91.1 in
Depth: 82.1 cm / 32.3 in
Features: Power unit incl. USB ports*



Model: JH80
Height: 72.5 cm / 28.5 in
Length: 126 cm / 49.6 in
Width: 75.9 cm / 29.8 in

* Available in select countries.

COFFEE TABLES

COFFEE TABLE SERIES

Design: Piet Hein/Arne Jacobsen, 1968

Fritz Hansen offers a wide range of coffee tables assembled from legendary design components, in keeping with the Table Series design DNA. Elegant coffee tables can be created to complement any interior design.

Table top: Laminate or veneer (walnut).

Base: Satin polished aluminium/chromed steel/ powder coated steel.



Model: A202 (Super-Circular™)
Height: 47 cm / 18.5 in
Length: 75 cm / 29.5 in
Width: 75 cm / 29.5 in



Model: A203 (Super-Circular™)
Height: 47 cm / 18.5 in
Length: 100 cm / 39.4 in
Width: 100 cm / 39.4 in



Model: A222 (Circular)
Height: 47 cm / 18.5 in
Diameter: 75 cm / 29.5 in



Model: A223 (Circular)
Height: 47 cm / 18.5 in
Diameter: 90 cm / 35.4 in

LITTLE FRIEND™

Design: Kasper Salto, 2005

Little Friend™ by Kasper Salto is a flexible, multifunctional and portable solution to the challenges of modern minimalistic working and living. It is perfect for a laptop as well as morning coffee.

Table top: Compact laminate (black or white) or veneer (oak or walnut).
Base: Chromed steel/Polished aluminium or lacquered steel.



Model: KS11
Height: 50-73 cm / 19.7-28.7 in
Diameter: 45 cm / 17.7 in
Features: Height adjustable



Model: KS12
Height: 60 cm / 23.6 in
Diameter: 45 cm / 17.7 in

TRAY TABLE

Design: Fritz Hansen, 1958

The Tray Table is a side table and a folding tray table. It was originally created for the staff of Fritz Hansen in 1958, but others quickly admired its organic shape and tapered legs and suggested the table be put into production.

Table top: Veneer (oiled oak or black lacquered oak).
Base: Solid wood (oiled oak or black lacquered oak).



Model: 840120 / 840121
Height: 42 cm / 16.5 in
Diameter: 45 cm / 17.7 in
Features: Foldable
Note: Accessories assortment



Model: 840122
Height: 39 cm / 15.4 in
Diameter: 60 cm / 23.6 in
Features: Foldable
Note: Accessories assortment

STUB

Design: Mette Schelde, 2020

Wood and glass merge smoothly within this unique table design. Inspired by a wooden 'stump', Stub (means 'stump' in Danish) has a clear glass circle that floats around the veneer base.

Table top: Veneer (oiled oak or black lacquered oak).
Base: Solid wood (oiled oak or black lacquered oak).



Model: MS11
Height: 44.5 cm / 17.52 in
Diameter: 49 cm / 19.29 in

JOIN™

Design: Fritz Hansen, 2014

The Join™ series was born out of a desire to create a flexible, light coffee table that could bring people and furniture together in one seamless union. The series has a subtle, understated expression and comes in three distinct shapes: a classic round table and two sizes of ovals.

Table top: Solid wood (oak or black coloured oak).
Base: Black powder coated steel.



Model: FH21
Height: 37 cm / 14.6 in
Length: 76 cm / 29.9 in
Width: 47 cm / 18.5 in



Model: FH41
Height: 37 cm / 14.6 in
Diameter: 80 cm / 31.5 in



Model: FH61
Height: 37 cm / 14.6 in
Length: 130 cm / 51.2 in
Width: 50 cm / 19.7 in



COFFEE TABLES

PLANNER™ TABLE SERIES

Design: Paul McCobb, 1953

The Planner™ coffee tables are part of a relaunched Fritz Hansen collection by Paul McCobb, a legendary designer known for creating slender designs where form follows function. Featuring a structured marble surface and a powder-coated steel base, the coffee table is an illustration of raw, tactile simplicity.

Table top: Marble (cream or charcoal).

Base: Black powder coated steel.



Model: MC300
Height: 40 cm / 15.7 in
Diameter: 80 cm / 31.5 in



Model: MC330
Height: 40 cm / 15.7 in
Length: 45 cm / 17.72 in
Width: 45 cm / 17.72 in



Model: MC310
Height: 40 cm / 15.7 in
Length: 75 cm / 29.5 in
Width: 45 cm / 17.7 in

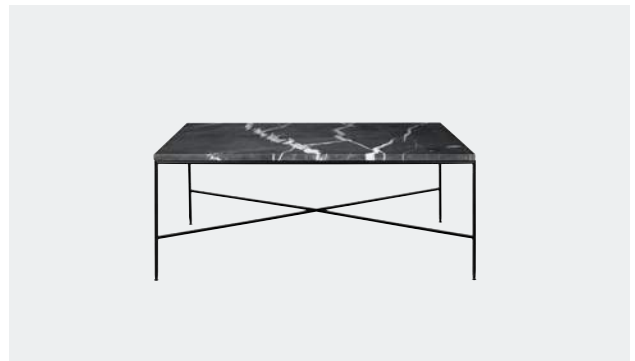

Model: MC340
Height: 40 cm / 15.7 in
Length: 100 cm / 39.37 in
Width: 100 cm / 39.37 in



Model: MC320
Height: 40 cm / 15.7 in
Length: 80 cm / 31.5 in
Width: 80 cm / 31.5 in



Model: MC350
Height: 40 cm / 15.7 in
Length: 130 cm / 51.18 in
Width: 70 cm / 27.56 in

COFFEE TABLES

AJ TROLLEY

Design: Arne Jacobsen, 1955

As a stainless steel bar cart, serving trolley or side table, this mobile design is versatile with a sophisticated, architectural edge. Arne Jacobsen originally designed this elegant trolley for his tea, and the design has remained 'modern' – and very useful.

Table top: Black coloured ash.
Base: Stainless steel hairline.



Model: 840410
Height: 54.7 cm / 21.5 in
Length: 67 cm / 26.5 in
Width: 59 cm / 23 in
Note: Accessories assortment

PK62™

Design: Poul Kjærholm, 1968

In 1968, Poul Kjærholm set out to design a series of tables that could be combined with his collection of lounge chairs and sofas. The resulting PK62™ was created in connection with the development of two other chairs: the PK20™ and PK24™. A design favourite, the statement side table features a satin-brushed stainless steel base and a tabletop made of slate, marble or granite.

Table top: Slate, marble or granite.
Base: Satin brushed stainless steel.



Model: PK62
Height: 17 cm / 6.7 in
Length: 80 cm / 31.5 in
Width: 27 cm / 10.6 in

PK63™

Design: Poul Kjærholm, 1968

In 1968, Poul Kjærholm set out to design a series of tables that could be combined with his collection of lounge chairs and sofas. The resulting PK63™ was created in connection with the PK31™ 2-seater and 3-seater sofas. The iconic coffee table features a satin-brushed stainless steel base and a tabletop made of slate, marble or granite.

Table top: Slate, marble or granite.
Base: Satin brushed stainless steel.



Model: PK63
Height: 31 cm / 12.2 in
Length: 180 cm / 70.9 in
Width: 60 cm / 23.6 in

PK63A™

Design: Poul Kjærholm, 1968

In 1968, Poul Kjærholm set out to design a series of tables that could be combined with his collection of lounge chairs and sofas. The resulting PK63A™ was created in connection with the PK31™ 2-seater and 3-seater sofas. The iconic coffee table features a satin-brushed stainless steel base and a tabletop made of slate, marble or granite.

Table top: Slate, marble or granite.
Base: Satin brushed stainless steel.



Model: PK63A
Height: 31 cm / 12.2 in
Length: 120 cm / 47.2 in
Width: 60 cm / 23.6 in

COFFEE TABLES

PK61™

Design: Poul Kjærholm, 1956

The PK61™ coffee table is as minimalistic as it gets from the hand of Poul Kjærholm. The square, aesthetic design serves as a powerful manifesto and shows Kjærholm's development from industrial designer to noteworthy furniture architect.

Table top: Slate, marble, granite or glass.
Base: Satin brushed stainless steel.



Model: PK61
Height: 32 cm / 12.6 in
Length: 80 cm / 31.5 in
Width: 80 cm / 31.5 in

PK61A™

Design: Poul Kjærholm, 1956

The PK61A™ is an enlarged version of Poul Kjærholm's PK61™ coffee table. Four base elements are joined with industrial screws to create a unique, distinguished look. The removable tabletop demonstrates Kjærholm's recurring principle of using gravity to keep the elements in place.

Table top: Marble, granite or glass.
Base: Satin brushed stainless steel.



Model: PK61A
Height: 32 cm / 12.6 in
Length: 120 cm / 47.2 in
Width: 120 cm / 47.2 in

PK65™

Design: Poul Kjærholm, 1979

This unique coffee table refers back to the best traditions of Scandinavian craftsmanship. As with several of his tables, Kjærholm created PK65™ to complement one or more of his many chairs and sofas; in this case, the PK20™ lounge chair.

Table top: Slate, marble, granite or glass.
Base: Satin brushed stainless steel.



Model: PK65
Height: 38 cm / 15 in
Length: 100 cm / 39.4 in
Width: 100 cm / 39.4 in

PK71™

Design: Poul Kjærholm, 1957

The PK71™ comprises of a series of three nesting tables, designed to be stored and stacked under each other. With their toy-like appearance, the small, abstract tables were designed to be shuffled around and used together or separate. Today, the PK71 are displayed in a permanent collection at the Museum of Modern Art in New York.

Table top: Acrylic (black or white).
Base: Satin brushed stainless steel.



Model: PK71
Height: 25.5, 27, 28.5 cm / 10, 10.6, 11.2 in
Length: 25, 26.5, 28 cm / 9.8, 10.4, 11 in
Width: 25, 26.5, 28 cm / 9.8, 10.4, 11 in

TABLES

TABLE SERIES™

Design: Piet Hein/Bruno Mathsson/Arne Jacobsen, 1968

Fritz Hansen offers a wide range of tables assembled from legendary design components. Elegant tables can be created to complement any interior design.

Table top: Laminate or veneer (walnut).

Base (column): Satin polished aluminium/chromed steel/ powder coated steel.

Base (span legs): Chromed or powder coated steel.



Model: B612 (Superellipse™)
 Height: 72 cm / 28.3 in
 Length: 150 cm / 59.1 in
 Length between legs: 92 cm / 36.2 in
 Width: 100 cm / 39.4 in
 Features: Detachable legs

Available in additional 5 sizes.



Model: B620 (Superellipse™)
 Height: 72 cm / 28.3 in
 Length: 170-270 cm / 66.9-106 in
 Width: 100 cm / 39.4 in
 Features: Extendable, Detachable legs

Available in additional 1 size.



Model: A622 (Circular)
 Height: 72 cm / 28.3 in
 Diameter: 75 cm / 29.5 in

Available in additional 1 size.



Model: A626 (Circular)
 Height: 72 cm / 28.3 in
 Diameter: 145 cm / 57.1 in

Available in additional 1 size.



Model: A602 (Supercircular™)
 Height: 72 cm / 28.3 in
 Length: 75 cm / 29.5 in
 Width: 75 cm / 29.5 in

Available in additional 1 size.



Model: B637 (Rectangular)
 Height: 72 cm / 28.3 in
 Length: 140 cm / 55.1 in
 Length between legs: 112 cm / 44.1 in
 Width: 80 cm / 31.5 in
 Features: Detachable legs

Available in additional 1 size.

Available in additional height

TABLES

FH125

Design: Piet Hein/Bruno Mathsson, 2019

The FH125 is a small, sophisticated dining table. Its rounded rectangular shape seats 4-6 and features a modern, white laminate top and elegant, aluminium edge.

Table top: Laminate (white).
Base: Chromed steel.



Model: FH125
Height: 72 cm / 28.3 in
Length: 125 cm / 49.2 in
Length between legs: 87 cm / 34.3 in
Width: 90 cm / 35.4 in
Features: Detachable legs



ANALOG™

Design: Jaime Hayon, 2014

Analog™ is not a square, not a circle, not an oval. Instead, designer Jaime Hayon fuses the best of all three classic shapes to create an entirely new and organic form. The result is a beautiful, wood-based platform for sharing meals and conversations.

Table top: Laminate (white) or veneer (oak or walnut).
Base: Solid wood (black lacquered oak, oak or walnut).



Model: JH43
Height: 72 cm / 28.3 in
Length: 130 cm / 51.2 in
Length between legs: 66 cm / 26 in
Width: 105 cm / 41.3 in



Model: JH63
Height: 72 cm / 28.3 in
Length: 185 cm / 72.8 in
Length between legs: 117 cm / 46.1 in
Width: 105 cm / 41.3 in



Model: JH83
Height: 72 cm / 28.3 in
Length: 245 cm / 96.5 in
Length between legs: 177 cm / 69.7 in
Width: 105 cm / 41.3 in

TABLES

ESSAY™

Design: Cecilie Manz, 2009

Essay™ is an exclusive table series in solid wood, created by Danish designer Cecilie Manz. The table consists of three elements - a tabletop and two bases - crafted in a simple, natural form. With its elegant look and flexible functionality, the table serves as the ideal gathering point in contemporary spaces.

Table top: White pigmented oak (solid wood)/ Oak (solid wood).

Base: White pigmented oak (solid wood)/ Oak (solid wood).

Extension leaf: Black laminate

(Length 48 cm/18.9 in, Width: 100 cm/39.4 in).



Model: CM12
Height: 72 cm / 28.3 in
Length: 190 cm / 74.8 in
Length between legs: 123 cm / 48.4 in
Width: 100 cm / 39.4 in
Features: Extendable



Model: CM22
Height: 72 cm / 28.3 in
Length: 230 cm / 90.5 in
Length between legs: 112 cm / 44.1 in
Width: 100 cm / 39.4 in
Features: Extendable



Model: CM32
Height: 72 cm / 28.3 in
Length: 265 cm / 104.3 in
Length between legs: 128 cm / 50.4 in
Width: 100 cm / 39.4 in
Features: Extendable



Model: CM42
Height: 72 cm / 28.3 in
Length: 295 cm / 116 in
Length between legs: 176 cm / 69.3 in
Width: 100 cm / 39.4 in
Features: Extendable

TABLES

PK54™

Design: Poul Kjærholm, 1963

The PK54™ dining table represents an exploration of contrasting materials and forms by Poul Kjærholm. Circle meets square, marble meets mineral – every time you look at it, new details emerge. Featuring Italian marble or granite and a satin-polished steel frame, the table's delicate unevenness makes it the natural focal point in any room.

Table top: Marble or granite.
Base: Satin brushed stainless steel.



Model: PK54
Height: 69 cm / 27.2 in
Diameter: 140 cm / 55.1 in
Features: Extendable (w. PK54A™)

PK54A™

Design: Poul Kjærholm, 1963

The PK54A™ extension ring provides a unique solution for those looking to extend the original PK54™ round dining table. Stone meets wood, hard meets soft – the table completely transforms appearance when the wooden extension ring is added. Perfect for plates around the table and a beautiful addition to the design.

Expansion ring: Solid wood (maple).
Storage unit: Solid wood (maple).



Model: PK54 + PK54A
Height: 70 cm / 27.6 in
Diameter: 210 cm / 82.7 in
Features: Storage unit

PK58™

Design: Poul Kjærholm, 1963/2007

PK58™ is a minimalist table inspired by PK54™ although the table is slightly taller with different materials. The proportions are still carefully considered and beautifully executed, with a blend of circular tabletop and a cube base with sharp angles.

Table top: Polyester composite (white).
Base: Anodised satin brushed aluminium.



Model: PK58
Height: 71 cm / 28 in
Diameter: 130 cm / 51.2 in

PK40™

Design: Poul Kjærholm, 1980

PK40™ is a unique version of Poul Kjærholm's square conference table with a leather-covered tabletop and a stainless steel base. The juxtaposition of materials is remarkable, a truly luxury design executed with full attention to detail.

Table top: Leather.
Base: Satin brushed stainless steel.



Model: PK40
Height: 70 cm / 27.6 in
Length: 140 cm / 55.1 in
Width: 140 cm / 55.1 in

TABLES

PLURALIS™

Design: Kasper Salto, 2016

As inferred by its name, the Pluralis™ table by Kasper Salto offers a myriad of possibilities. Characterised by its understated design, elegance and uncompromising quality, it brings a whole new level of functionality to the workspace.

Table top: Wood, Laminate, Linoleum.
Base: Polished or powder coated aluminium.

Accessories: Cable management etc.

Features: Overhang on one or two end(s), options of table widths.



Model: KS420
Height: 72 cm / 28.3 in
Length: 160 cm / 63.0 in
Length between legs: 146 cm / 57.5 in
Width: 80 cm / 31.5 in



Model: KS421
Height: 72 cm / 28.3 in
Length: 200 cm / 78.7 in
Length between legs: 188 cm / 74.0 in
Width: 80 cm, 90 cm or 100 cm / 31.5 in, 35.4 in or 39.4 in



Model: KS422
Height: 72 cm / 28.3 in
Length: 240 cm / 94.5 in
Length between legs: 228 cm / 89.8 in
Width: 80 cm, 90 cm, 100 cm or 120 cm / 31.5 in, 35.4 in, 39.4 in or 47.2 in



Model: KS423
Height: 72 cm / 28.3 in
Length: 320 cm / 126.0 in
Length between legs: 150 cm / 59.3 in
Width: 90 cm, 100 cm or 120 cm / 35.4 in, 39.4 in or 47.2 in



TABLES

PK51™

Design: Poul Kjærholm, 1957

The PK51™ is an iconic rectangular worktable handcrafted in 1957 by Poul Kjærholm. Characterised by an ash veneer tabletop and a satin-brushed stainless steel frame, the table was originally launched together with PK11™ as a matching set.

Table top: Ash veneer.
Base: Satin brushed stainless steel.



Model: PK51
Height: 72 cm / 28.3 in
Length: 204 cm / 80.3 in
Width: 102 cm / 40.2 in

PK55™

Design: Poul Kjærholm, 1957

The PK55™ is an iconic rectangular worktable handcrafted in 1957 by Poul Kjærholm. Characterised by an ash veneer tabletop and a satin-brushed stainless steel frame, the PK55 was launched as a smaller version of the PK51™.

Table top: Ash veneer.
Base: Satin brushed stainless steel.



Model: PK55
Height: 72 cm / 28.3 in
Length: 180 cm / 70.9 in
Width: 90 cm / 35.4 in

BAR TABLE SERIES

Design: Piet Hein/Arne Jacobsen, 1968

Fritz Hansen offers a wide range of bar tables assembled from legendary design components, in keeping with the Table Series design DNA. Elegant bar tables can be created to complement any interior design.

Table top: Laminate or veneer (walnut).
Base: Satin polished aluminium/satin chromed steel/ powder coated steel.



Model: A902 (Super-Circular™)
Height: 108 cm / 42.5 in
Length: 75 cm / 29.5 in
Width: 75 cm / 29.5 in



Model: A922 (Circular)
Height: 108 cm / 42.5 in
Diameter: 75 cm / 29.5 in

SHELVING

PLANNER™ SHELVING

Design: Paul McCobb, 1952

Designed by the late Paul McCobb, a pioneer of contemporary democratic design, the Planner™ Shelving series combines his signature graphic aesthetic with elegant expression. Named after its ability to help shape the design of a room, the simple yet striking shelving is available in three versions, each in varying heights and configurations.

Shelves: Oak veneer.

Base: Black powder coated steel.



Model: MC500
Height: 84.4 cm / 33.2 in
Width: 120.7 cm / 47.5 in
Depth: 38.1 cm / 15 in



Model: MC510
Height: 123.2 cm / 48.5 in
Width: 120.7 cm / 47.5 in
Depth: 38.1 cm / 15 in



Model: MC520
Height: 165 cm / 65 in
Width: 120.7 cm / 47.5 in
Depth: 38.1 cm / 15 in



ACCESSORIES

RUGS

Design: Cecilie Manz, 2020

Handmade rugs add colour and sophisticated dimension at floor level. Various tufting heights within each design make them subtly three-dimensional and tactically interesting.

Material: 100% wool, handtufted.



Name: Balance
Model: 840401
Length: 130 cm / 51.1 in
Width: 103 cm / 40.5 in

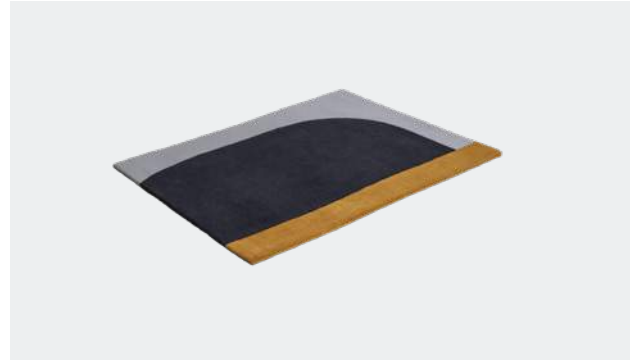

Name: Ochre
Model: 840403
Length: 130 cm / 51.1 in
Width: 103 cm / 40.5 in



Name: Dotted Balance
Model: 840402
Length: 130 cm / 51.1 in
Width: 103 cm / 40.5 in



Name: Dots
Model: 840400
Length: 190 cm / 75 in
Width: 150 cm / 59 in

LIGHTING

AEON ROCKET™

Design: Morten Voss, 2012



Category: Pendant
Model: P1
Height: 23.6 cm / 9.2 in
Diameter: 40 cm / 15.7 in
Colour: Aeon-Grey, Aeon-Black



Category: Pendant
Model: P3
Height: 33.2 cm / 12.9 in
Diameter: 60 cm / 23.6 in
Colour: Aeon-Grey, Aeon-Black



AQ01™

Design: Anne Qvist, 2017



Category: Table lamp
Height: 44 cm / 17.3 in
Width: 45 cm / 17.7 in
Colour: White, Black, Blue
Features: Tilttable, Swivel, Dimmable



Category: Table lamp (Plug-in)
Height: 45.3 cm / 17.8 in
Width: 45 cm / 17.7 in
Colour: White, Black, Blue
Features: Tilttable, Swivel, Dimmable

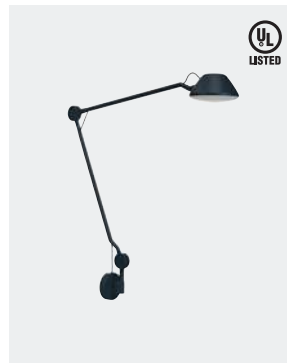

Category: Wall lamp
Height: 48.3 cm / 17.8 in
Width: 45 cm / 17.7 in
Colour: White, Black, Blue
Features: Tilttable, Swivel, Dimmable

AVION™

Design: Iskos-Berlin, 2012



Category: Pendant
Height: 34.2 cm / 13.5 in
Width: 85 cm / 33.5 in
Colour: White

CALABASH™

Design: Komplot Design, 2010

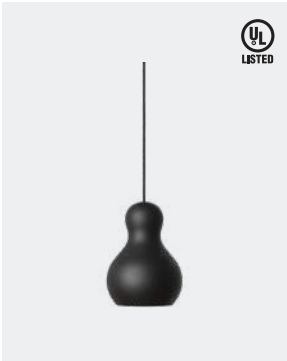

Category: Pendant
 Model: P1
 Height: 21 cm / 8.3 in
 Diameter: 15.8 cm / 6.2 in
 Colour: Gold, Silver, Grey Meteor, Black Meteor



Category: Pendant
 Model: P2
 Height: 30.5 cm / 12 in
 Diameter: 22.4 cm / 8.8 in
 Colour: Gold, Silver, Grey Meteor, Black Meteor

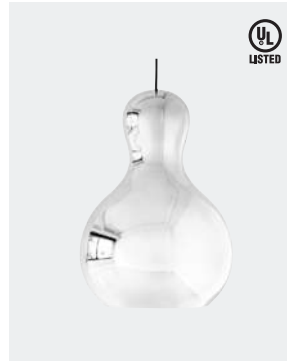

Category: Pendant
 Model: P3
 Height: 48.4 cm / 19 in
 Diameter: 34 cm / 13.4 in
 Colour: Silver

CARAVAGGIO™

Design: Cecilie Manz, 2005



Category: Pendant
 Model: PO LED
 Height: 14.5 cm / 5.7 in
 Diameter: 11 cm / 4.3 in
 Colour: Opal

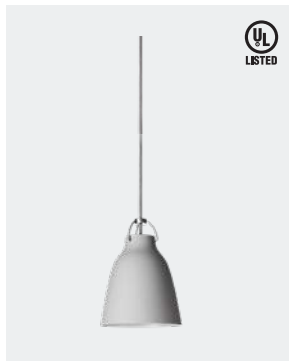

Category: Pendant
 Model: P1
 Height: 21.6 cm / 8.5 in
 Diameter: 16.5 cm / 6.4 in
 Colour: White, Black, BlackBlack, White (matt), Grey25, Grey45, Black (matt), Opal



Category: Pendant
 Model: P2
 Height: 33.7 cm / 13.2 in
 Diameter: 25.8 cm / 10.1 in
 Colour: White, Black, BlackBlack, White (matt), Grey25, Grey45, Black (matt), Opal



Category: Pendant
 Model: P3
 Height: 51.6 cm / 20.3 in
 Diameter: 40 cm / 15.7 in
 Colour: White, Black, BlackBlack, White (matt), Grey25, Grey45, Black (matt), Opal

CONCERT™

Design: Jørn Utzon, 2005



Category: Pendant
 Model: P1
 Height: 16.6 cm / 6.4 in
 Diameter: 32 cm / 12.5 in
 Colour: White



Category: Pendant
 Model: P3
 Height: 32 cm / 12.5 in
 Diameter: 55 cm / 21.6 in
 Colour: White

CLAM™

Design: Ahm & Lund



Category: Pendant
 Model: Ø440
 Height: 52.2 cm / 20.5 in
 Diameter: 44 cm / 17.3 in
 Colour: Opal glass/ brass



Category: Pendant
 Model: Ø550
 Height: 54 cm / 21.3 in
 Diameter: 55 cm / 21.7 in
 Colour: Opal glass/ brass

CARAVAGGIO™ READ

Design: Cecilie Manz, 2005



Category: Wall lamp
 Height: 20.6 cm / 8.1 in
 Width: 35 cm / 13.7 in
 Colour: White, Grey25, Black, Opal
 Features: Tilttable, Swivel

ORIENT™

Design: Jo Hammerborg, 1963

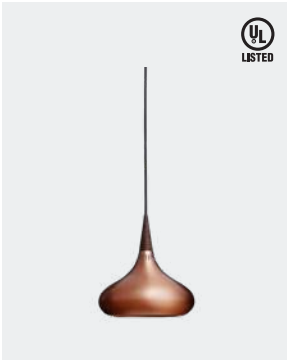

Category: Pendant
 Model: P1
 Height: 24.5 cm / 9.6 in
 Diameter: 22.5 cm / 8.8 in
 Material/Colour: Aluminium/Oak,
 Black/Rosewood, Copper/Rosewood



Category: Pendant
 Model: P2
 Height: 37 cm / 14.5 in
 Diameter: 34 cm / 13.3 in
 Material/Colour: Aluminium/Oak,
 Black/Rosewood, Copper/Rosewood

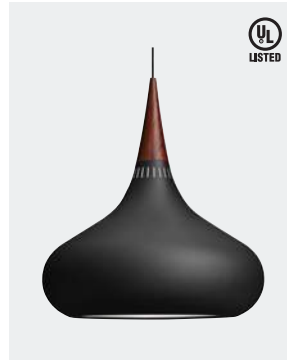

Category: Pendant
 Model: P3
 Height: 54 cm / 21.2 in
 Diameter: 50 cm / 19.6 in
 Material/Colour: Aluminium/Oak,
 Black/Rosewood

CROSS-PLEX™

Design: Bodil Kjær, 1961



Category: Table lamp
 Model: T-300
 Height: 30 cm / 11.8 in
 Width: 40 cm / 15.8 in
 Colour: Opal/Clear



Category: Table lamp
 Model: T-500
 Height: 50 cm / 19.7 in
 Width: 20 cm / 7.9 in
 Colour: Opal/Clear

DOGU™

Design: Michael Geertsen, 2016



Category: Pendant
 Height: 32.9 cm / 13 in
 Diameter: 24 cm / 9.5 in
 Material/Colour: Bone china/Gold,
 Bone china/Silver

KAISER idell™

Design: Christian Dell, 1931



Category: Pendant
Model: 6722-P
Height: 15.5 cm / 6.1 in
Diameter: 14.5 cm / 5.7 in
Colour: Black, Russet red, Soft ochre, Smooth slate

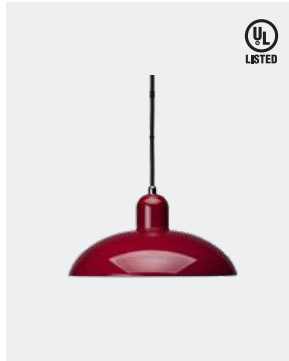

Category: Pendant
Model: 6631-P
Height: 13.5 cm / 5.3 in
Diameter: 28.5 cm / 11.2 in
Colour: White, Black, Matt black, Ruby red

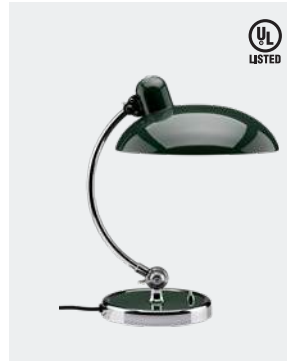

Category: Table lamp
Model: 6631-T Luxus
Height: 42.5 cm / 16.7 in
Diameter (shade): 28.5 cm / 11.2 in
Diameter (base): 19.4 cm / 7.6 in
Colour: White, Black, Matt black*, Ruby red, Dark green, Easy Grey*
Features: Tilttable
* Available with Brass or standard Chrome elements



Category: Table lamp
Model: 6556-T
Height: 47 cm / 18.5 in
Diameter (shade): 21.5 cm / 8.5 in
Diameter (base): 18.5 cm / 7.3 in
Colour: White, Black, Matt Black, Easy Grey*
Features: Tilttable
* Available with Brass elements



Category: Floor lamp
Model: 6580-F Luxus
Height: 125-135 cm / 49.2-53.1 in
Diameter (shade): 21.5 cm / 8.5 in
Diameter (base): 22.5 cm / 8.9 in
Colour: White, Black, Matt black
Features: Height adjustable, Swivel



Category: Floor lamp
Model: 6556-F
Height: 125 cm / 49.2 in
Diameter (shade): 21.5 cm / 8.5 in
Diameter (base): 22.5 cm / 8.9 in
Colour: White, Black, Matt black, Easy Grey*
Features: Tilttable
* Available with Brass elements

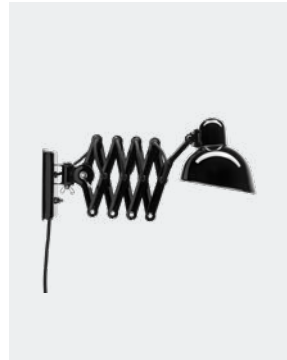

Category: Wall lamp
Model: 6718-W
Height (base): 14.8 cm / 5.8 in
Diameter (shade): 16.4 cm / 6.5 in
Width: 47-89 cm / 18.5-35 in
Colour: White, Black, Matt black
Features: Stretchable, Swivel

MALUMA™

Design: Fumie Shibata, 2021



Category: Pendant
Model: H350
Height: 35 cm / 13.8 in
Diameter: 23.5 cm / 9.3 in
Colour: Rose, Plum, Moss

NIGHT OWL™

Design: Nikolai Wiig Hansen, 2015



Category: Table lamp
Height: 23.9 cm / 9.4 in
Diameter: 23.5 cm / 9.2 in
Colour: Midnight blue, Smokey white, Midnight blue/Ash, Smokey white/Ash

LIGHTING

SILHUET

Design: Jo Hammerborg, 1977



Category: Pendant
Model: P2
Height: 32.8 cm / 12.9 in
Diameter: 29.5 cm / 11.6 in
Colour: Brushed brass, Polished brass

SUSPENCE™

Design: GamFratesi, 2013



Category: Pendant
Model: P1
Height: 22.5 cm / 8.8 in
Diameter: 24 cm / 9.4 in
Colour: White, Light grey, Black, Copper

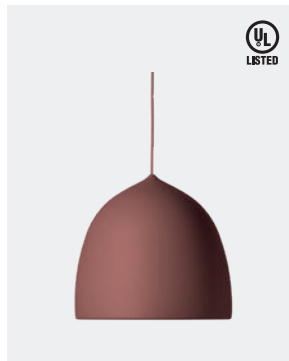

Category: Pendant
Model: P1.5
Height: 29.8 cm / 11.7 in
Diameter: 32 cm / 12.6 in
Colour: Light grey, Powder burgundy, Pale yellow



Category: Pendant
Model: P2
Height: 36 cm / 14.2 in
Diameter: 38.5 cm / 15.1 in
Colour: White, Light grey, Black, Copper

PM-02

Design: Paul McCobb, 1950



Category: Table lamp
Height: 31.4 cm / 12.3 in
Diameter: 13.6 cm / 5.3 in
Colour: Opal/Black, Opal/Brass



VASES



Model: Ikebana Vase
Designer: Jaime Hayon
Height: 15.5 cm / 6.1 in
Diameter: 24 cm / 9.4 in
Material: Glass/Brass

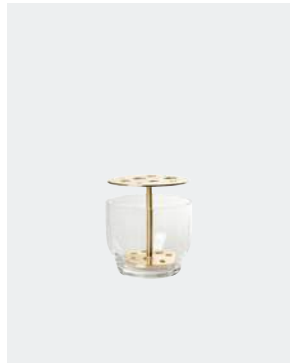

Model: Ikebana Vase Small
Designer: Jaime Hayon
Height: 13 cm / 5.1 in
Diameter: 12 cm / 4.7 in
Material: Glass/Brass



Model: Ikebana Vase Long
Designer: Jaime Hayon
Height: 13 cm / 5.1 in
Length: 33.5 cm / 13.2 in
Width: 9.5 cm / 3.7 in
Material: Glass/Brass



Model: Moon Eye Vase
Designer: Grethe Meyer
Height: 23 cm/9.1 in, 16 cm/6.3 in
Width: 16 cm/6.3 in, 13.5 cm/5.3 in
Depth: 8 cm/3.1 in, 8 cm/3.1 in
Colour: Clear and Smoked/Clear glass



Model: Ikeru Vase High
Designer: Jaime Hayon
Height: 23.9 cm / 9.4 in
Diameter: 16 cm / 6.3 in
Material: Forest green glass/Aluminium



Model: Ikeru Vase Low
Designer: Jaime Hayon
Height: 13.1 cm / 5.1 in
Diameter: 19 cm / 7.4 in
Material: Forest green glass/Aluminium



ACCESSORIES

CANDLEHOLDERS



Model: Louise Candleholder
Designer: Grethe Meyer
Height: 2.1 cm / 0.8 in
Diameter: 6.9 cm / 2.7 in
Material: Silver plated stainless steel

CANDLEHOLDERS



Model: Candleholder Single #1
Designer: Jaime Hayon
Height: 10.5 cm / 4.1 in
Diameter: 5 cm / 2 in
Colours: Brass



Model: Candleholder Single #2
Designer: Jaime Hayon
Height: 13 cm / 5.1 in
Diameter: 4 cm / 1.6 in
Colours: Brass

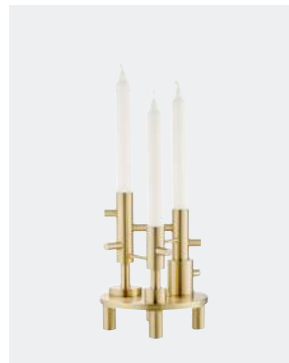

Model: Candleholder Large
Designer: Jaime Hayon
Height: 20 cm / 7.9 in
Diameter: 16 cm / 6.3 in
Material: Brass



Model: Candleholder Single #1
Designer: Jaime Hayon
Height: 10.5 cm / 4.1 in
Diameter: 5 cm / 2 in
Colours: Stainless steel



Model: Candleholder Single #2
Designer: Jaime Hayon
Height: 13 cm / 5.1 in
Diameter: 4 cm / 1.6 in
Colours: Stainless steel



Model: Candleholder Large
Designer: Jaime Hayon
Height: 20 cm / 7.9 in
Diameter: 16 cm / 6.3 in
Material: Stainless steel

CUSHIONS



Model: Cushion Vertigo
 Designer: Arne Jacobsen
 Height: 50 cm / 19.7 in
 Width: 50 cm / 19.7 in
 Colour: Light grey



Model: Cushion Vertigo
 Designer: Arne Jacobsen
 Height: 40 cm / 15.7 in
 Width: 60 cm / 23.6 in
 Colour: Light grey



Model: Cushion Trapez
 Designer: Arne Jacobsen
 Height: 50 cm / 19.7 in
 Width: 50 cm / 19.7 in
 Colours: Midnight blue



Model: Cushion Trapez
 Designer: Arne Jacobsen
 Height: 40 cm / 15.7 in
 Width: 60 cm / 23.6 in
 Colours: Midnight blue



Model: Cushion Tassel
 Designer: Arne Jacobsen
 Height: 45 cm / 17.7 in
 Width: 45 cm / 17.7 in
 Colour: Ochre yellow



Model: Cushion Tassel
 Designer: Arne Jacobsen
 Height: 36 cm / 14.1 in
 Width: 56 cm / 22 in
 Colour: Ochre yellow



Model: Cushion
 Designer: Alayu
 Height: 40 cm / 15.7 in
 Width: 60 cm / 23.6 in
 Colours: Anthracite, Oat

THROWS



Model: Throw
 Designer: Jaime Hayon
 Length: 200 cm / 78.7 in
 Width: 130 cm / 51.2 in
 Colour: Gold



Model: Throw Cashmere
 Designer: Fritz Hansen
 Length: 190 cm / 74.8 in
 Width: 120 cm / 47.2 in
 Colour: Natural brown



Model: Classic Throw
 Designer: Fritz Hansen
 Length: 180 cm / 70.9 in
 Width: 130 cm / 51.2 in
 Colour: Grey

ACCESSORIES

COAT RACKS



Model: Coat Tree™ Wall
Designer: Sidse Werner
Height: 104 cm / 40.9 in
Width: 46 cm / 18.1 in
Depth: 30 cm / 11.8 in
Colours: Light grey, Dark blue



Model: Coat Tree™
Designer: Sidse Werner
Height: 193 cm / 76 in
Diameter: 65 cm / 25.6 in
Colour: Chrome
Note: Furniture assortment

HAPPY HOOK



Model: Happy Hook
Designer: Jaime Hayon
Height: 13 cm / 5.1 in
Width: 15 cm / 5.9 in
Depth: 6.5 cm / 2.5 in
Colours: Green grey, Blush, Dark turquoise

SLIDE



Model: Slide
Designer: Karin Nakamura
Height: 29.8 cm / 11.7 in
Length: 44 cm / 17.3 in
Depth: 14.3 cm / 5.6 in
Material: Smoked glass/Hand-cast concrete/Cork/Ash wood

BOXES



Model: Leather Box Small
Designer: August Sandgren
Height: 6.5 cm / 2.5 in
Length: 26 cm / 10.2 in
Width: 20.5 cm / 8 in
Material: Pure leather/Linen

DESK



Model: Wave
Designer: Hiromichi Konno
Height: 12 cm / 4.7 in
Width: 18 cm / 7.1 in
Depth: 16 cm / 6.3 in
Material: Soft coated steel/Leather
Colour: Black

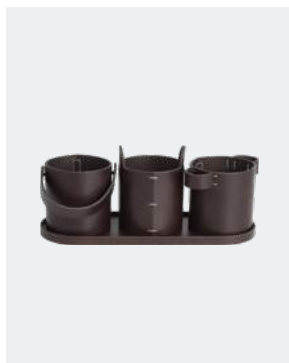

Model: Buckets
Designer: Mia Lagerman
Height: 12 cm / 4.7 in
Width: 30 cm / 11.8 in
Depth: 10.5 cm / 4.1 in
Material: Harness leather
Colour: Brown



Model: Desk Pad
Designer: Hiromichi Konno
Width: 55 cm / 21.7 in
Depth: 40 cm / 15.7 in
Material: Royal Nubuck leather
Colour: Lava grey

ACCESSORIES

MAGAZINE HOLDER



Model: Magazine Holder
Designer: Paul McCobb
Height: 45 cm / 17.7 in
Width: 33 cm / 13 in
Depth: 33 cm / 13 in
Material: Black powder coated steel/
Black-white textile

POUFS



Model: Pouf Large
Designer: Cecilie Manz
Height: 29 cm / 11.4 in
Diameter: 60 cm / 23.6 in
Colours: Concrete, Indigo, Beige



Model: Pouf Small
Designer: Cecilie Manz
Height: 24 cm / 9.5 in
Diameter: 50 cm / 19.7 in
Colours: Slate, Ultramarine,
Light Grey Leather

MIRRORS



Model: Table Mirror
Designer: Paul McCobb
Height: 51 cm / 20.1 in
Width: 32 cm / 12.6 in
Depth: 25 cm / 9.8 in
Materials: Black powder coated steel/
White Carrara marble



Model: Wall Mirror
Designer: Paul McCobb
Height: 157 cm / 61.8 in
Width: 39-75 cm / 15.3-29.5 in
Depth: 22 cm / 8.7 in
Materials: Black powder coated steel/
White Carrara marble

MINIATURES

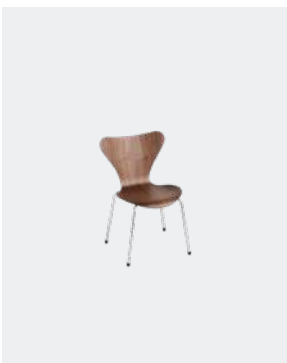

Model: Miniature Series 7™
Designer: Arne Jacobsen
Height: 13 cm / 5.1 in
Width: 8.5 cm / 3.3 in
Colours: Black, Opium red, Walnut



Model: Miniature Egg™
Designer: Arne Jacobsen
Height: 16.5 cm / 6.4 in
Width: 13.5 cm / 5.3 in
Colours: Black, Red

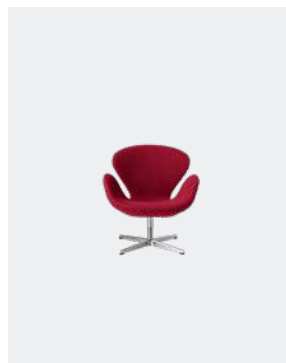

Model: Miniature Swan™
Designer: Arne Jacobsen
Height: 9 cm / 3.5 in
Width: 13.5 cm / 5.3 in
Colours: Black, Red

ACCESSORIES

SIDE TABLES



Model: Tray Table
Designer: Fritz Hansen
Height: 42 cm / 16.5 in
Diameter: 45 cm / 17.7 in
Materials: Oak, Black lacquered oak



Model: Tray Table Large
Designer: Fritz Hansen
Height: 39 cm / 16.5 in
Diameter: 60 cm / 17.7 in
Materials: Black lacquered oak



Model: AJ Trolley
Designer: Arne Jacobsen
Height: 54.7 cm / 21.5 in
Width: 67 cm / 26.5 in
Depth: 59 cm / 23 in
Material: Black coloured ash/
Stainless steel

STOOLS



Model: Dot™
Designer: Arne Jacobsen
Height: 46 cm / 18.1 in
Width: 34 cm / 13.4 in
Depth: 34 cm / 13.4 in
Colours: Black/Powder coated black,
Walnut/Chrome, Lava grey/Chrome



Model: High Dot™
Designer: Arne Jacobsen
Height: 65 cm / 25.6 in
Width: 44 cm / 17.3 in
Depth: 44 cm / 17.3 in
Colours: Black/Powder coated black,
Walnut/Chrome, Lava grey/Chrome

BASKET



Model: Basket
Designer: Benjamin Hubert
Height: 36.5 cm / 14.4 in
Length: 53 cm / 20.8 in
Width: 37 cm / 14.6 in
Material: Ash veneer

CHILDREN'S CHAIRS



Model: Series 7™ Children's Chair
Designer: Arne Jacobsen
Height: 60 cm / 23.6 in
Seat height: 34 cm / 13.3 in
Width: 40 cm / 15.7 in
Depth: 42 cm / 16.5 in
Colours: Black, Lavender Blue, Rose



Model: Series 7™ Junior
Designer: Arne Jacobsen
Height: 79 cm / 31.1 in
Seat height: 52 cm / 20.4 in
Width: 42 cm / 16.5 in
Depth: 44 cm / 17.3 in
Colour: Black, Oak

FRITZ HANSEN

DESIGN COLLECTION

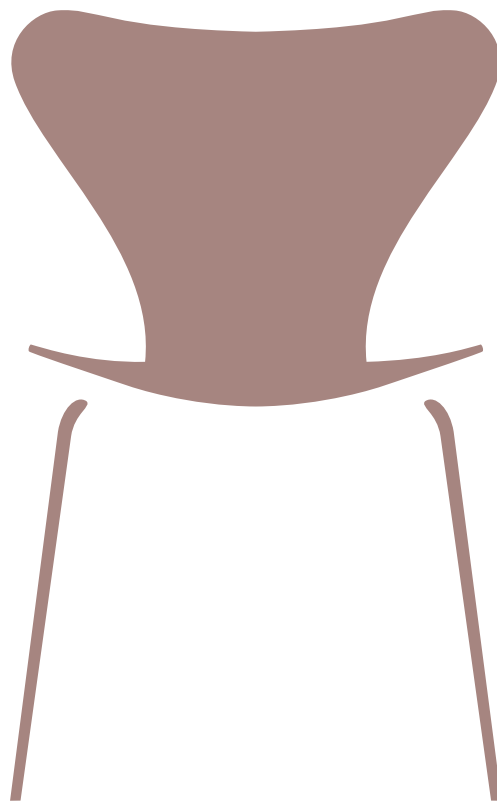

FURNITURE LIGHTING ACCESSORIES

EXTRAORDINARY DESIGN SINCE 1872

Welcome to a world of design, craftsmanship and beauty. Here, you'll find more than 100 years of Danish design tradition and collaborations with visionary architects, designers and artists from around the world.

Welcome to Fritz Hansen.

Since 1872, Fritz Hansen has been crafting extraordinary design that transforms the everyday into something special. By continuously pushing the boundaries of design and craftsmanship we shape the world for those who wish to be inspired, intrigued and surprised.

THIS IS NO ORDINARY DESIGN

Founded in Denmark in 1872, Fritz Hansen is a global leader in furniture, lighting and accessory design and production. Driven by a passion for beauty, quality, and craftsmanship, the company embodies a modern, Nordic lifestyle and collaborates with visionary artists, designers, and architects from around the world. The brand has collaborated with Arne Jacobsen, Cecilie Manz, Hans J. Wegner, Piero Lissoni, and Poul Kjærholm, among others.

Today Fritz Hansen designs are sold in more than 85 countries through 2,000 points of sale, including flagship stores in Copenhagen, San Francisco, New York and Tokyo. The company employs approximately 260 people worldwide and maintains its headquarters north of Copenhagen, serving design-passionate customers through contract and retail.



Egg™ lounge chair by Arne Jacobsen in Vidar textile.



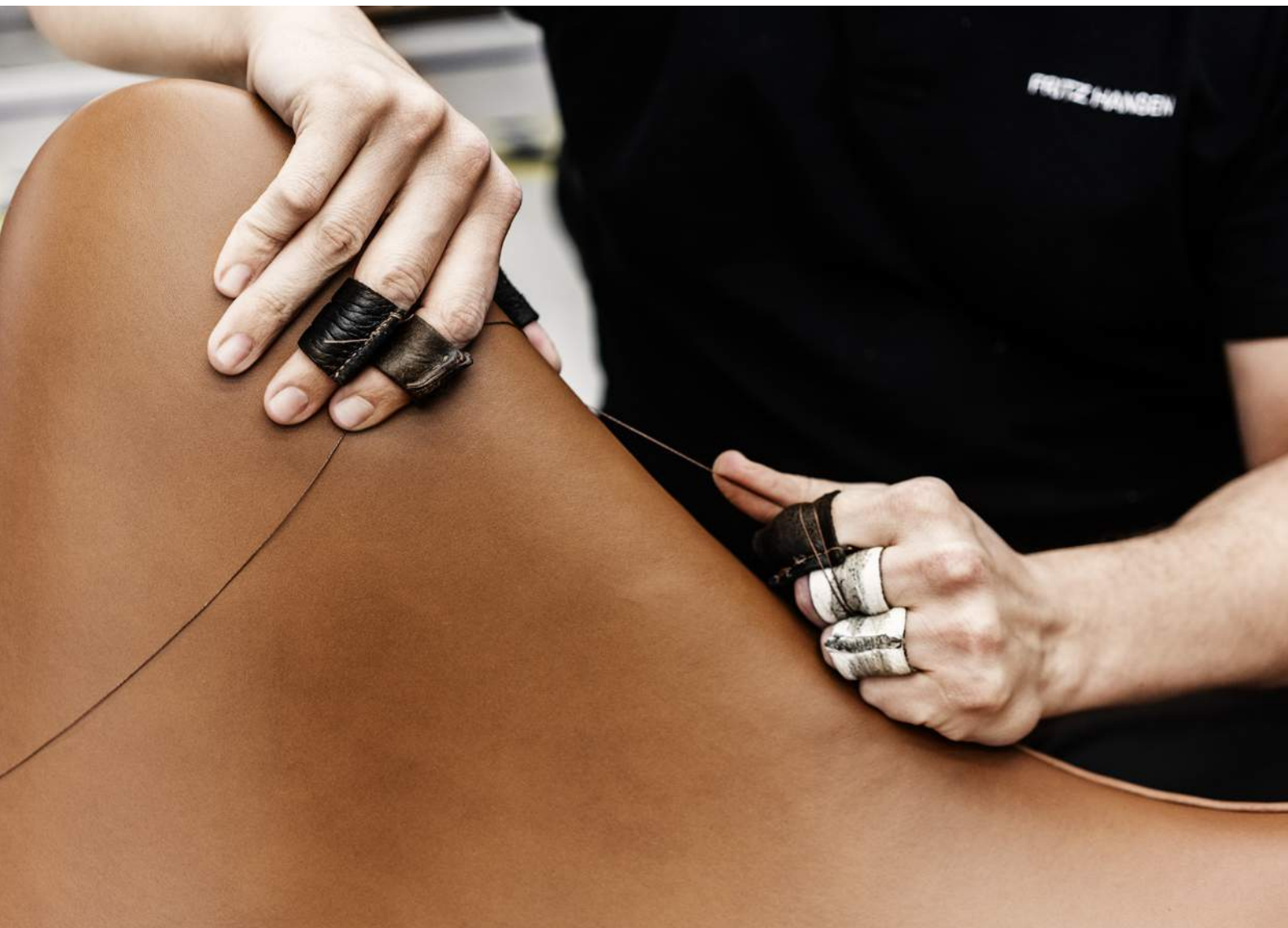

LONGEVITY & SUSTAINABILITY

We believe that premium quality and sustainability go hand in hand.

At Fritz Hansen, we are working with social, environmental and economic considerations to find sustainable solutions, without compromising on quality.

From careful sourcing to operating our own factory on green electricity, we believe the details matter - in design and process.

LIFELONG LOVE AFFAIR

Do natural imperfections make great designs more beautiful?

Opinions of beauty are linked to people's deepest desires and inherent values, which is perhaps why they can often seem so strong and visceral. That, too, is simply natural. Attitudes towards the natural wear of materials differ too. Patina and the natural beauty marks displayed over time on materials such as metal, stone and leather are admired by some and disliked by others.

In some cases, vintage furniture designs with patina are prized by collectors for their uniqueness. The visible age of a given piece becomes a source of pride; its changes are a natural and poetic reminder that nature is mutable. On the other hand, the desire for consistency is natural too, and linked to peace of mind. Some prefer slower change and less sensitivity from the space around them, favouring an evergreen look with materials that have been coloured and treated to stay relatively consistent over time.

The beauty of objects is how different they are from us, how they stand still and steady in the everchanging world. Differences of opinion and in preference are, after all, only natural.





Lily™ chair by Arne Jacobsen in walnut veneer and the **Superellipse™** table with span legs by Bruno Mathsson and form by Piet Hein.

CLASSIC DESIGN

A Danish design bridges Chinese antiquity
and new Nordic taste.

The China Chair™ was designed by Hans J. Wegner in 1944. Inspired by the timeless aesthetic of ancient Chinese design in the 17th and 18th centuries, the China Chair epitomises his lifelong quest to understand the nature of wood and explore its possibilities. In this modern interpretation, he unfolded his talent as a wood craftsman and his flair for expressive and sculptural functionalism.



China Chair™ designed by Hans J. Wegner in cherry wood



Decorative objects gather behind a living room door as the **China Chair™**, designed by Hans J. Wegner, sneaks into the frame.

SIMPLE ELEGANCE



Poul Kjærholm & Fritz Hansen

A trained cabinetmaker who completed his studies at the Danish School of Arts and Crafts, Poul Kjærholm had a particular interest in construction materials – especially steel, which he considered a material deserving the artistic respect that was commonly awarded to wood.

Poul Kjærholm initiated a collaboration with furniture manufacturer Ejvind Kold Christensen in 1955, which continued for the rest of Kjærholm's life with the two families remaining close to this day.

Two years after the designer's death, the Kjærholm trustees entrusted Fritz Hansen with the production and sales of The Kjærholm Collection – designs developed by Poul Kjærholm from 1951 to 1980.

Fritz Hansen is honoured to continue production and to distribute Poul Kjærholm's furniture to architects and private customers around the world.





A **PK22™** chair in wicker and **PK61™** coffee table in satin-polished stainless steel and grey brown honed marble by Poul Kjærholm, with an **Ikeru** vase by Jaime Hayon.





PK80™ daybed, **PK61™** coffee table, **PK25™** chair, **PK91™** folding Stool, all by Poul Kjærholm. **Planner™** shelving by Paul McCobb, a **KAISER idell™** floor lamp by Christian Dell and **Ikebana** vase by Jaime Hayon also shown.

PK80™ daybed
designed by Poul Kjærholm
in canvas.



TRANSPARENT DESIGN

For Poul Kjærholm, simplicity was essential. He insisted on materials of the highest quality and designed for transparency. Indeed, nothing in Kjærholm's designs is unnecessary or cosmetic.



PK61™ coffee table designed by Poul Kjærholm in satin-polished stainless steel and glass.

LUXURY LIVES ON

True luxury withstands the test of time in terms of design and craftsmanship. Whether from the great masters of furniture design or the rising stars of tomorrow, Fritz Hansen seeks to continue the design traditions of the past while creating the next generation of design classics for the future.



PK9™ chair and **PK54™** table designed by Poul Kjærholm under an **Orient™** pendant by Jo Hammerborg.





Arne Jacobsen's luxurious **Lily™** chair in Walnut catches the sunlight in Tokyo.

NEW BASICS

Bases are available in Chrome, Black, Nine Grey, Brown Bronze, Silver Grey, Warm Graphite and White, supporting dining, meeting and task seating.

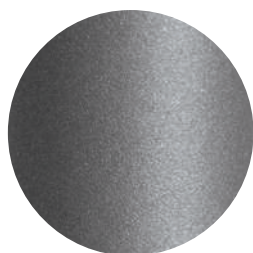

SILVER GREY

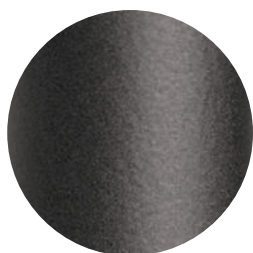

WARM GRAPHITE

Match the chair bases* with other Fritz Hansen furniture bases, including the Table Series, stacking chairs, Egg™ and Swan™ chairs by Arne Jacobsen, and the Lissoni Sofa™ Series.

This creates a system of Fritz Hansen colours and finishes that can be used across an entire project.

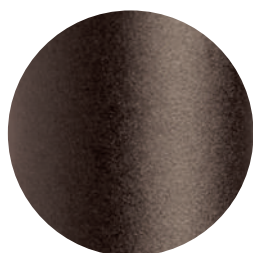

BROWN BRONZE

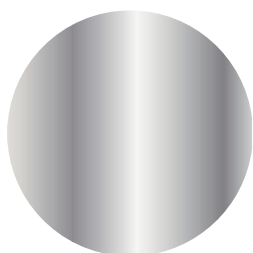

CHROMED /
POLISHED STEEL

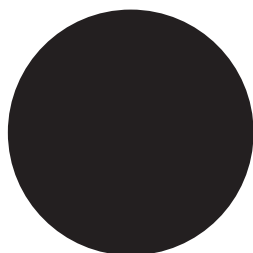

BLACK

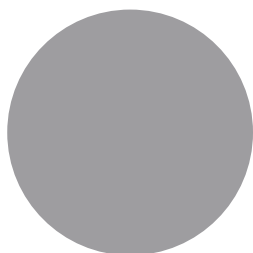

NINE GREY

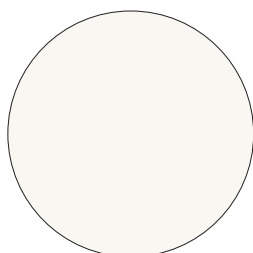

WHITE

* The colour availability differs depending on the products.



The **Egg**™ chair by Arne Jacobsen adds organic curves to an interior design.



Series 7™ chair by Arne Jacobsen in lacquered Light Beige with Warm Graphite base and front upholstery. Black **Superellipse™** table under grey **Caravaggio™** lamp by Cecilie Manz.

NEW NORDIC DINING

The eye-catching Caravaggio™ pendant was launched in 2005 and instantaneously gained status as a design icon. With its simple, elegant and recognisable shape it has set the standard as a new classic in lighting design.



Black **Superellipse™** table
by Piet Hein, Bruno
Mathsson & Arne Jacobsen
with laminate table top and
Warm Graphite base.



A SENSE OF COLOUR



16 CAREFULLY CURATED COLOURS

Carefully curated in collaboration with Carla Sozzani, each colour has been developed to not only complement the natural materials of the designs, but to also complement each other.

Explore a new palette of sixteen compatible colours and seven bases for Ant™, Grand Prix™ and Series 7™ chairs by Arne Jacobsen.





LIVING WITH COLOURS

A stunning new dimension of colours and textiles for the iconic Series 7™ chair by Arne Jacobsen. Create your very own unique combination and add a touch of colour to any home and any room.





A HINT OF GREEN

Series 7™ chair by Arne Jacobsen in Evergreen with Brown Bronze base and front upholstery in Sunniva 3.

A DASH OF YELLOW

Series 7™ chair by Arne Jacobsen in True Yellow with Brown Bronze base and front upholstery in Remix 2.

ADMIRING ARNE JACOBSEN

Why the Italian editor, gallerist and businesswoman
Carla Sozzani collects Arne Jacobsen design.

Carla Sozzani is well known as the founder of 10 Corso Como, the Milanese concept store – and quite possibly the first of its kind in the world – which she founded in 1991. She is also a gallerist and editor, having worked with the likes of Bruce Weber and Herb Ritts and collaborated with Azzedine Alaïa and Rei Kawakubo. She has curated exhibitions with Annie Leibovitz, Helmut Newton, David La Chapelle and Steven Meisel in her own gallery and at the Maison Européenne de la Photographie in Paris, among other locations. What many don't know is that Sozzani is also a long-time admirer and collector of Danish design.

Her fascination with Arne Jacobsen's work began in the '70s and has continued for almost 50 years. Today, Arne Jacobsen chairs can be found at 10 Corso Como, Sozzani's studio, and in her home.

'Harmony is the secret of any environment, and it only develops over time. For me it is like this: I can add more and more Eggs, Swans, Drops or Series 7 to my interiors, while at the same time they appear as if they were there for the first time or always. You see?' she says.

The organic shape of Arne Jacobsen designs captivates Sozzani, who describes the Series 7 chair as 'sensual.' The design, she explains, is so organic that it is almost like a human form. You can dress it up in any colour and it takes on a new attitude.

Sozzani pulls out her iPhone to share photographs of pieces from her personal collection, and a rare, vintage Jacobsen design that she is currently hunting for.

*Carla Sozzani has collaborated with Fritz Hansen on a new palette of 16 colours for iconic Arne Jacobsen designs, released in 2020.





ADD A TOUCH OF COLOUR TO ANY ROOM

Green, blue, pink, brown, red or yellow? Whatever your desired expression, Arne Jacobsen chair designs can reflect the sentiment with sixteen carefully curated colours and seven base options.



Grand Prix™ chair in True Yellow with Warm Graphite base and **Circular™** table in Walnut veneer by Arne Jacobsen. The grey **Suspence™** pendant is designed by GamFratesi.





Drop™ chair in Olive Green with Warm Graphite base

THE REBELLIOUS ARNE JACOBSEN



Arne Jacobsen & Fritz Hansen

It is said that as a child growing up in Copenhagen, Arne Jacobsen painted over the Victorian wallpaper in his bedroom. But young Arne did not cover his walls with typical childish drawings or paint the ornate wallpaper boyish blue. Instead, he decided to paint his room entirely white.

His decision may seem commonplace today, but in the early twentieth century white walls were not yet in fashion. From the very beginning, Arne Jacobsen was ahead of his time.

For more than half of the twentieth century, Arne Jacobsen's ideas shaped the landscape of Danish design, rippling out from Scandinavia to influence architects and designers around the world. He directed projects ranging from complex buildings like Denmark's National Bank to meticulous challenges as humble as a special teaspoon for his cutlery set, working with a relatively small studio staff driven by an unquenchable desire to create.

Jacobsen's creative process centred on his strict consideration of detail. He brought his visions to life for patrons and builders with scrupulous, hand-painted watercolour sketches. In any given year, Jacobsen managed to design what others might be happy to produce in five.



A PEARL OF LIGHT



Clam™ pendant, designed by Ahm & Lund shown together with **PK54™**, **PK54A™** and **PK9™** by Poul Kjærholm.

Crafted in mouth blown glass and brass, the Clam™ pendant designed by Ahm & Lund is a modern lighting innovation with a timeless aesthetic.



Mouth blown opal glass and brushed brass come together – and move apart – to create elegant, adjustable and atmospheric lighting for dining and

living spaces. Equally elegant open as it is closed, the perfectly balanced design elevates any room with its considered combination of form and ambience.



The **Fred™** lounge chair, designed by Jaime Hayon, is assembled by hand. The low, open profile and curved armrests invite relaxation.

Fred™ lounge chairs by Jaime Hayon draw inspiration from the pelican's broad wings, gently curved body and distinctive bill. The sculpted frame of the chair is crafted from eight individual pieces of wood, digitally cut before being carefully finished and assembled by hand.

All wooden chair frames are FSC-certified. Christianshavn™ textiles add another dimension of sustainability with EU Ecolabel and OEKO-TEX® STANDARD 100 certifications.



THE ART OF LOUNGING

‘Comfort was a key factor, as was the combination of the best of Danish design craftsmanship and modern technology,’ says Jaime Hayon about the new Fred™ lounge chair, featured here in clear lacquered oak.



Lune™ sofa and Fred™ chairs designed by Jaime Hayon in Pink 1131 Christianshavn™ fabric surround a Planner™ coffee table designed by Paul McCobb.







Ro™ chair and footstool designed by Jaime Hayon, a **KAISER idell™** floor lamp with a **Rug** designed by Cecilie Manz underfoot.



A **Ro™** footstool is the perfect place to put your feet up.



Leather **Egg™** chair
by Arne Jacobsen and
Fritz Hansen-designed
Tray Table.



AJ Trolley by Arne Jacobsen.





The modular **Alphabet Sofa™** series by Piero Lissoni offers flexible comfort. Arrange at will to create a unique space.



Lissoni Sofa™ by Pierro Lissoni in Christianshavn fabric and black base.

ELEGANT BY DESIGN

Characterised by clean lines and flawless attention to detail, the Lissoni Sofa™ series has a distinct aesthetic that elevates and adds character to any room and from any angle.





Lissoni Sofa™ by Piero Lissoni in Remix fabric and Warm Graphite base.

Fri™ chair by Jaime Hayon,
and **KAISER idell™** floor lamp.

HOME ACCORDING TO JAIME HAYON



Jaime Hayon
Hayon Studio

WHAT DEFINES GOOD DESIGN?

‘Good design is primarily design that lasts. Design must have something to say; it must be able to improve our quality of life and be meaningful. But for me, design is not just about function – it’s also about feelings, and I like if it provokes a little and can challenge our way of life.’

WHAT MAKES A SPACE FEEL LIKE HOME?

‘A room is homey when the lighting and the atmosphere come together; when the music matches the place, and when the combination of colours and light makes me feel happy. I also like to be able to feel what is happening outside. I don’t like being in pent up spaces, where daylight is excluded or where materials and furniture are cold, or where I get cold feet.’





Planner™ coffee table
by Paul McCobb.

PLANNER™ DESIGNS

Paul McCobb's innate understanding of perspective paved the way for a career as one of the most important design figures of his time. The self-taught designer's pragmatic yet perfectionist nature was reflected in his work, characterised by slender, graphic lines, a simplicity of form and lightness of design.



Magazine Holder by Paul McCobb.



PM-02 table lamp
by Paul McCobb.



Planner™ coffee table by Paul McCobb together with
Cross-Plex™ lamp by Bodil Kjær.



Planner™ shelving by Paul McCobb.



KAISER idell™ Luxus by Christian Dell in brass and matt black is a bold pairing of reflective warmth and cool darkness.



EMBRACING MODERN LIFE

The N01™ chair fuses Danish and Japanese design sensibilities into nine layers of pressure-moulded veneer and solid wood legs. Millimetre by millimetre, the design is an illustration of beauty and functionality. Available in beech, oak and black lacquered oak.



N01™ armchair in black coloured oak by nendo.



Suspence™ pendant by GamFratesi over the **Superellipse™** table by Piet Hein, Bruno Mathsson & Arne Jacobsen and **NO1™** chairs in oak by nendo.



An **Essay™** table by Cecilie Manz in natural oak, surrounded by **Series 7™** chairs by Arne Jacobsen in Dusk Blue, Midnight Blue and Lavender Blue with coloured bases.



A PROFOUND SENSE OF DETAILS

Cecilie Manz's universe revolves around her love of art, and the names of her products often pay tribute to her favourite creative minds.



Cecilie Manz

Over the course of her career, Danish designer Cecilie Manz has shown an impeccable ability to create lamps, ceramics, home accessories and furniture design that continually unite the Scandinavian tradition of simplicity with a modern, international expression.

While her work tends to abide by the 'form follows function' philosophy, each design is also imbued with a serene beauty. Pieces are understated yet present themselves to the world with an artistic twist.

REMARKABLY ELEGANT



FH125 table for city life and smaller spaces.



Ant™ chairs by Arne Jacobsen in Ever Green, Olive Green and White with coloured bases together with **Calabash™** pendants by Komplot Design.



INSPIRED BY IKEBANA

'Ikebana is often translated to Japanese floral art or flower arrangement,' says Tomoko Sempo Yanagi, an Ikebana professor and the chairperson of Ikenobo UK & Ireland, 'But, in my view, Ikebana isn't just an artistic arrangement of flowers and plants, the practice is as spiritual as it is technical.'



Ikebana vases by Jaime Hayon come in three variants.



Ikebana Small vase designed by Jaime Hayon.

Dating back to the seventh century when Buddhists started offering flowers at temple altars, ikebana was later formalised in the 16th century by emperors and aristocrats. The practice also has roots in the ancient Shinto religion – a belief system that conceives ‘god,’ or ‘spirits,’ as residing in natural phenomena such as trees, flowers and wind. Today, the art form is practiced by professionals and amateurs alike.

At its core, ikebana involves carefully selecting plants and flowers to create a form that honours natural characteristics when placed in a new environment.

Ikebana and Ikeru vases by Spanish designer Jamie Hayon are created in the spirit of the practice and its meditation on nature. The modern vases are designed to honour every flower placed within them, from stem to crown.



Ikeru High vase
by Jaime Hayon.



Night Owl™ table lamp
by Nikolai Wiig Hansen

SMALL AND STYLISH

Elevate the everyday for a little one with extraordinary design on a smaller scale. Children's chairs by Arne Jacobsen in a variety of colours and Happy Hooks by Jaime Hayon are two popular picks for design enthusiasts in the making.

Happy Hook coat hanger by Jaime Hayon.





Series 7™ children's chair by Arne Jacobsen in coloured ash together with **Rug Ochre** by Cecilie Manz and **Happy Hook** by Jaime Hayon.

Maluma™ pendants
designed by Fumie Shibata.



BRIGHT IDEAS

Pleasant interior lighting shapes mood, improves productivity and conserves energy. Scandinavian winters are long and dark and summer days are long and bright. Fritz Hansen's collection of timeless lighting design focuses on overall impact: turned on or left off, indoor lighting should be beautiful.





The harmonious and striking **Aeon Rocket™** pendant, designed by Morten Voss.

AESTHETIC AMBIENCE

Concert™ is world-famous, Danish design. The unique shade configuration is visually characteristic of architect Jørn Utzon's design ethos.

The pendant's diffuser is handcrafted using triple-layered, mouth-blown opal glass and distributes pleasant, even light to make it a noteworthy centrepiece for dining rooms and other gathering places.



Cross-Plex™ lamp designed by Bodil Kjær.





The multi-layered **Concert™** pendant showcases Jørn Utzon's architectural language.



Leather **Buckets** by Mia Lagerman
on the **Pluralis™** table by Kasper Salto.



Oxford™ chair by Arne Jacobsen and
the **Pluralis™** table by Kasper Salto,
with **KAISER idell™** table lamp next to
Planner™ shelving by Paul McCobb and
and **Pouf** by Cecilie Manz.

WORKING HOURS

The right work setup can assist focus, improve posture and make working hours more productive – and pleasant.







Leather **Series 7™** chair by Arne Jacobsen with swivel base and **Pluralis™** table by Kasper Salto, with **Planner™** shelving by Paul McCobb and **KAISER idell™** table lamp by Christian Dell.



Classic Throw on the **PK63™** coffee table by Poul Kjærholm.

Coat Tree™ Wall
by Sidse Werner in dark blue.



Pouf, in two sizes, and
Rug by Cecilie Manz.



High Dot™ in leather,
designed by Arne Jacobsen.

Candleholder in stainless steel
designed by Jaime Hayon.



THE LITTLE THINGS

At home and work, accessories add beauty and life to our interiors. Fritz Hansen accessories always marry form and function with high quality craftsmanship.

Slide storage
designed by Karin Nakamura.



Stub table by Mette Schelde
together with **Let™** lounge chair
by Sebastian Herkner.

Stub table
by Mette Schelde in coloured
ash with glass table top.





STAY AWHILE

Let™ lounge chairs by Sebastian Herkner profile the German designer's skills and aesthetic and Fritz Hansen's expert craftsmanship.

HOUSEHOLD PLASTIC WASTE REDESIGNED

A multi-purpose chair made from recycled plastic household waste that can be recycled once more wherever PP5 plastic bottles are accepted. Learn more at www.fritzhansen.com



N02™ Recycle seating by Nendo in monochrome colour with **Super-Circular™** cafe tables from the Fritz Hansen **Table Series™**.





The **NO2™ Recycle** is Fritz Hansen's first chair made with a circular plastic shell.

TAKE IT EASY

A good chair is one of life's little luxuries, essential for long visits, enjoying a drink or getting work done. Fritz Hansen seating is tested for quality and comfort, designed with precision to fit beautifully into everyday life and spaces.



Arne Jacobsen's **High Dot™** bar stools for the bar or kitchen counter.



Pot™ chair by Arne Jacobsen is a timeless example of embracing comfort.



VIA57™ chairs designed by Bjarke Ingels and KiBiSi,
Tray Table by Fritz Hansen and **Little Friend™** by Kasper Salto.



Little Friend™ table by Kasper Salto is the ideal resting place for a laptop or morning mug of coffee. Easy to move and always useful.

PLENUM™

Plenum™ one-seater by Jaime Hayon is adjustable to your work environment, with optional power plugs, USB outlets (available in select countries) and side tables.





Plenum™ two-seater by Jaime Hayon.

RESTORATIVE BREAKS

Can contentment be designed? What about productivity or happiness? Much is out of our control, but we can set the scene for good conversations, great meetings and restorative breaks. A good seat is the first step.

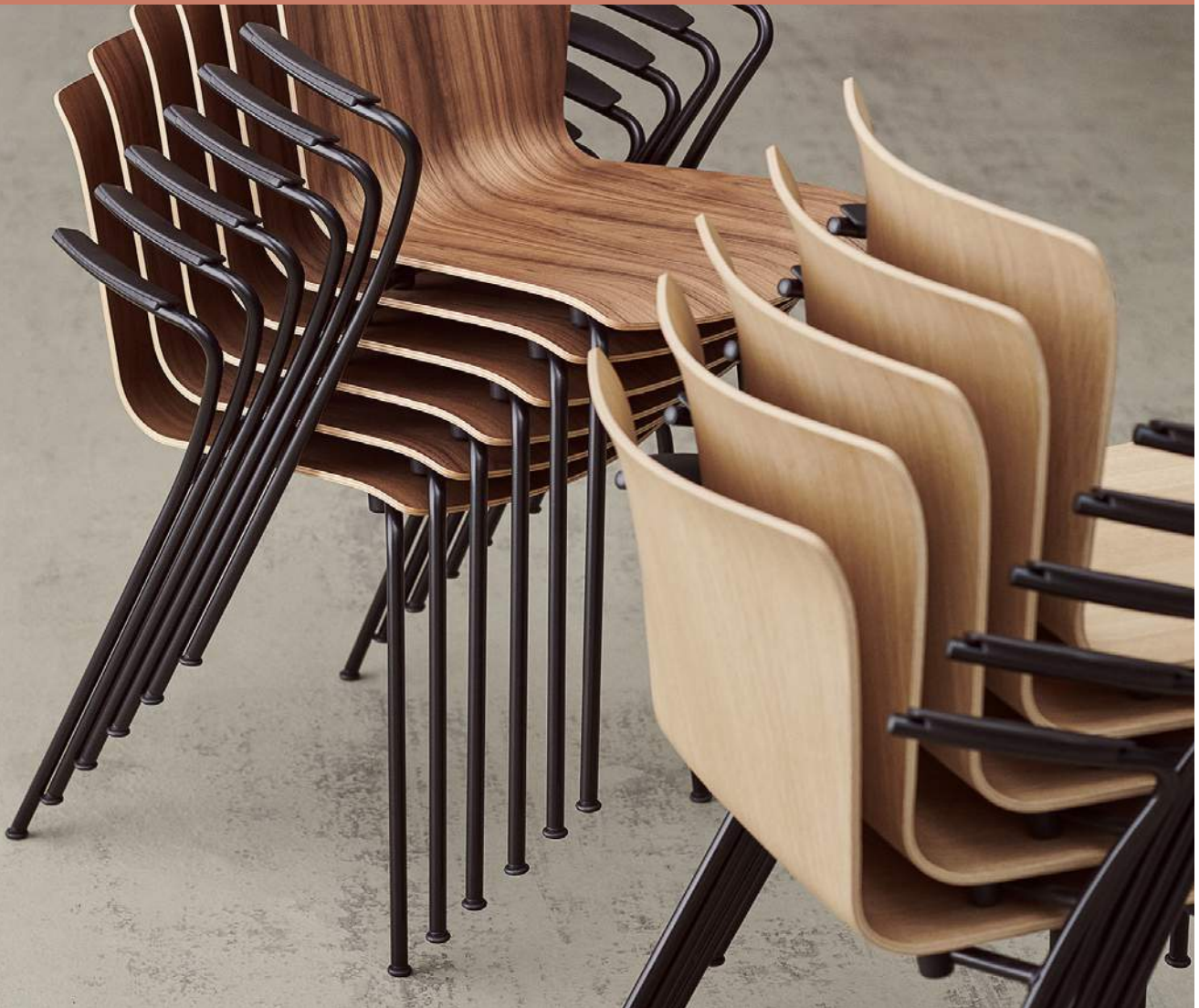



Vico Duo™ chair by Vico Magistretti.

ROOM FOR IMAGINATION





PROJECTS



SKY PATIO BY RYUNIQUE

Location: Dongtan, South Korea

Category: Hospitality

Area: Retail

Architect: Conran & partners

Products: Series 7™, Egg™, Swan™, Ro™, Fri™, Drop™, Grand Prix™, Suspence™, Planner™, Table Series™

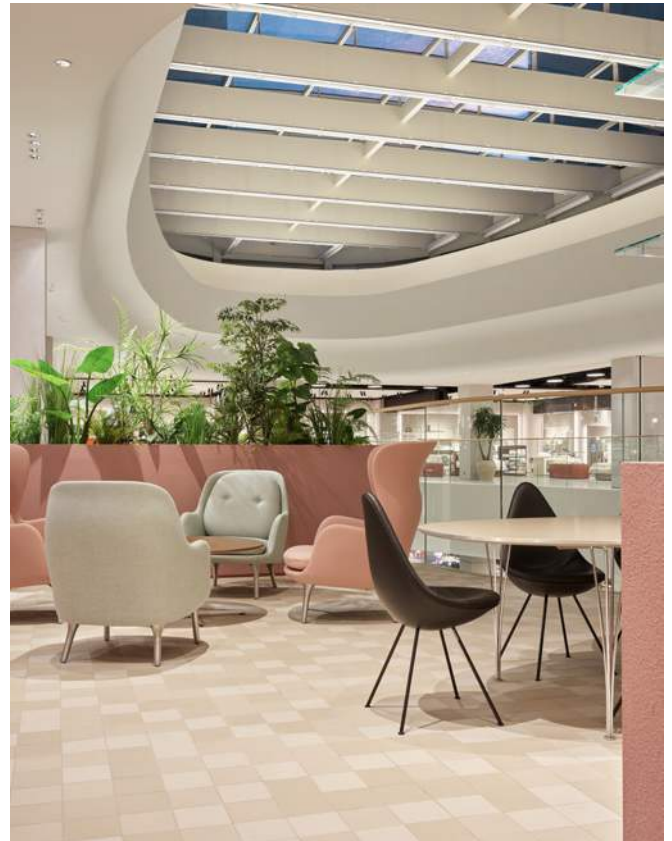



VIA57™ seating and large **Caravaggio™** pendants in the Media Library of Capucins.

MEDIA LIBRARY OF CAPUCINS

Location: Brest, France
Category: Culture
Areas: Public area, Library
Architect: Canal (atelier d'architecture)

Products: VIA57™, Caravaggio™



Photos: Thomas Lang

LEGO HOUSE

Location: Billund, Denmark
Category: Culture
Areas: Dining, Restaurant
Architect: Bjarke Ingels Group
Products: Grand Prix™

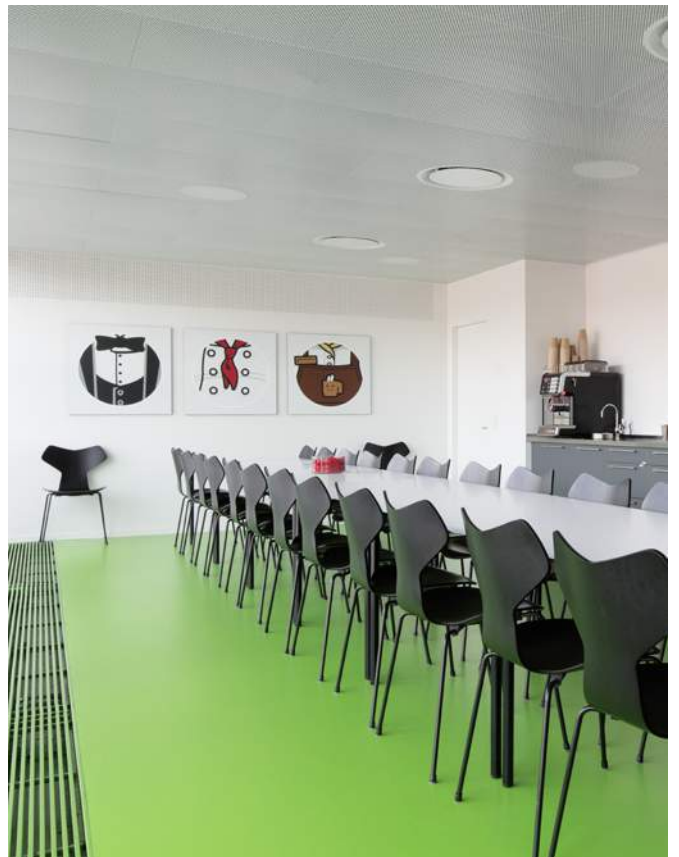

XIAN MAIKE CENTRE BOOKSTORE

Location: Xi'an, China

Category: Culture/Hospitality

Areas: Public area, Library

Interior design: Tomoko Ikegai (ikg.inc.)

Products: Swan™, Coffee Table Series



Swan™ seating
by Arne Jacobsen
mirrors the curves of
the central staircase.



Credit: Designer: Tomoko Ikegai (ikg inc.), Photographer: Nacasa&Partners, Design cooperation: A Factory inc. / Japan Power Media Co, Ltd., Lighting: Sola Associates, Graphic Design: ujdesign.



AGERN

Location: New York, United States

Category: Hospitality

Areas: Restaurant

Architect: Christina Meyer Bengtsson

Products: Grand Prix™, Orient™



Grand Prix™ seating is geometric, offsetting the wood paneling at the restaurant Agern in New York.

KEUNE HAIRCOSMETIC

Location: Tbilisi, Georgia
Category: Retail/Healthcare
Areas: Clinic

Products: Fri™, Ro™, Favn™,
Series 7™



Fritz Hansen seating by Jaime Hayon and Arne Jacobsen adds quiet charm in soft colours.



CARLSBERG

Location: Copenhagen, Denmark

Category: Office

Areas: Canteen, Boardroom, Meeting rooms

Architect: Vivianna Schøttz Andersen,
C.F.Møller

Products: Grand Prix™, Little Giraffe™





OFENHAUS

Location: Augsburg, Germany
Category: Hospitality
Areas: Restaurant & Bar
Architect: Innenarchitektur Büro Kolb

Products: Pot™, Caravaggio™, Series 7™

Pot™ and **Series 7™** seating with bold **Caravaggio™** pendants add pops of colour in the otherwise industrial space.



PRODUCTS

CHAIRS

SERIES 7™

Design: Arne Jacobsen, 1955

The Series 7™ chair is an icon in modern furniture history, designed by Arne Jacobsen in 1955. Its unique shape is timeless and incredibly versatile, displaying character without overpowering the eye. The chair is made from 9 layers of pressure moulded veneer for strength, flexibility and durability despite its slender form. This is the most popular design within Fritz Hansen's chair collection.

Shell: Coloured ash, lacquered and natural veneer or front- and fully upholstered in a wide range of textiles and leather types.

Base: Chromed or powder coated steel.

Accessories: Felt glides, Seat cushion, Linking device etc.



Model: 3107
 Height: 82 cm / 32.2 in
 Seat height: 46 cm / 18.1 in
 Width: 50 cm / 20 in
 Depth: 52 cm / 20.5 in
 Features: Stackable

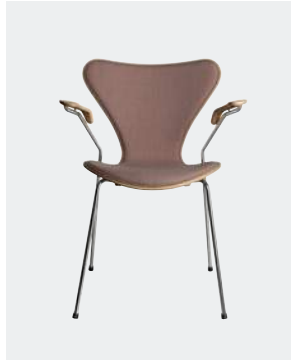

Model: 3207
 Height: 80 cm / 30.9 in
 Seat height: 46 cm / 18.1 in
 Armrest height: 69.5 cm / 27.4 in
 Width: 61 cm / 24 in
 Depth: 52 cm / 20.5 in



Model: 3117
 Height: 78-90 cm / 30.7-35.4 in
 Seat height: 44-56 cm / 17.3-22 in
 Width: 50 cm / 20 in
 Depth: 52 cm / 20.5 in



Model: 3217
 Height: 78-90 cm / 30.7-35.4 in
 Seat height: 44-56 cm / 17.3-22 in
 Armrest height: 66-78 cm / 26.4-31.1 in
 Width: 61 cm / 24 in
 Depth: 52 cm / 20.5 in

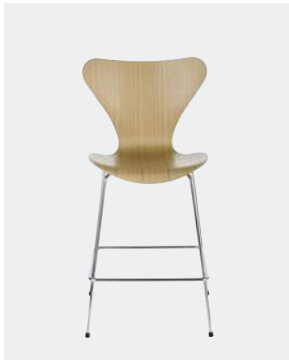

Model: 3187
 Height: 98 cm / 38.6 in
 Seat height: 64 cm / 25.2 in
 Width: 52 cm / 20.5 in
 Depth: 54 cm / 21.3 in

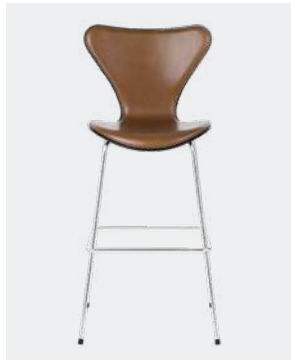

Model: 3197
 Height: 110 cm / 43.3 in
 Seat height: 76 cm / 29.9 in
 Width: 53 cm / 20.9 in
 Depth: 59 cm / 23.2 in



Model: Children's Chair
 Height: 60 cm / 23.6 in
 Seat height: 34 cm / 13.3 in
 Width: 40 cm / 15.7 in
 Depth: 42 cm / 16.5 in
 Note: Accessories assortment



Model: Junior
 Height: 79 cm / 31.1 in
 Seat height: 52 cm / 20.4 in
 Width: 42 cm / 16.5 in
 Depth: 44 cm / 17.3 in
 Note: Accessories assortment



CHAIRS

ANT™

Design: Arne Jacobsen, 1952

The Ant™ chair's visual expression is delicate and artful, much like the curves of a musical instrument. Designed by Arne Jacobsen in 1952, the chair is made from nine layers of pressure moulded veneer. Its elegant shape disguises its remarkable strength and comfort.

Shell: Coloured ash, lacquered, natural veneer.

Base: Chromed or powder coated steel.

Accessories: Felt glides, Linking device etc.

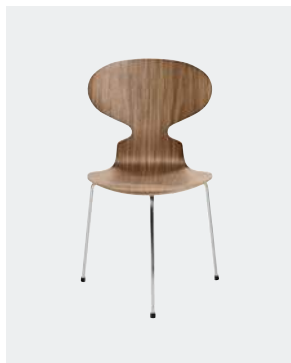

Model: 3100
Height: 77 cm / 30.3 in
Seat height: 44 cm / 17.3 in
Width: 52 cm / 20.4 in
Depth: 51 cm / 20 in
Features: Stackable



Model: 3101
Height: 81 cm / 31.9 in
Seat height: 46 cm / 18.1 in
Width: 52 cm / 20.4 in
Depth: 48 cm / 18.9 in
Features: Stackable

GRAND PRIX™

Design: Arne Jacobsen, 1957

The Grand Prix™ chair is a chair with graphic edge. It was introduced at the Designers' Spring Exhibition at the Danish Museum of Art & Design in 1957. Later that year, the chair was displayed at the Triennale in Milan where it received the Grand Prix, the finest distinction of the exhibition. The celebrated chair comes in both a steel or wood base and can be customised through a series of colours, wood types and upholstery.

Shell: Coloured ash, lacquered (3130 model only) and natural veneer (oak and walnut) or front- and fully upholstered in textile and leather.

Base: Chromed and powder coated steel or wooden legs.

Accessories: Felt glides, Linking device etc.

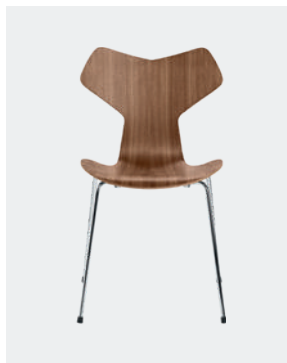

Model: 3130
Height: 83 cm / 32.7 in
Seat height: 46 cm / 18.1 in
Width: 48 cm / 18.9 in
Depth: 51 cm / 20.1 in
Features: Stackable

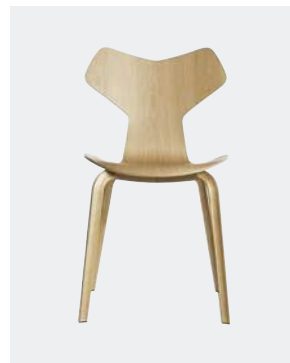

Model: 4130
Height: 83 cm / 32.7 in
Seat height: 46 cm / 18.1 in
Width: 50 cm / 19.7 in
Depth: 51 cm / 20.1 in

LILY™

Design: Arne Jacobsen, 1970

Arne Jacobsen first created the sleek, curvaceous Lily™ chair for Danmarks Nationalbank. Its characteristic wide shoulders and slim waist are striking examples of Jacobsen exploring and challenging the possibilities of veneer to create perfect curves and offer ultimate comfort.

Shell: Natural veneer (walnut) or fully upholstered in textile and leather.

Base: Chromed steel.

Accessories: Felt glides.

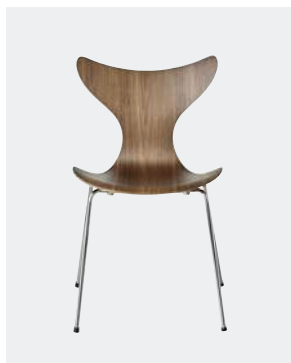

Model: 3108
Height: 83 cm / 32.6 in
Seat height: 46 cm / 18.1 in
Width: 54 cm / 21.2 in
Depth: 49 cm / 19.2 in
Features: Stackable



Model: 3208
Height: 83 cm / 32.6 in
Seat height: 46 cm / 18.1 in
Armrest height: 71 cm / 28 in
Width: 62 cm / 24.4 in
Depth: 49 cm / 19.2 in

DROP™

Design: Arne Jacobsen, 1958

The Drop™ chair draws inspiration from the feeling of an embrace, but it has also been designed for freedom of movement; creating a unique sense of comfort. Designed by Arne Jacobsen, it was originally created for the SAS Royal Hotel in Copenhagen before being relaunched in 2014. It is said to be Jacobsen's favourite chair among his many designs.

Shell: Plastic or fully upholstered in textile and leather.

Base: Chromed and powder coated steel.

Accessories: Seat cushion, Felt glides.



Model: 3110
Height: 88.5 cm / 34.8 in
Seat height: 46 cm / 18.1 in
Width: 45.5 cm / 17.9 in
Depth: 54.5 cm / 21.5 in

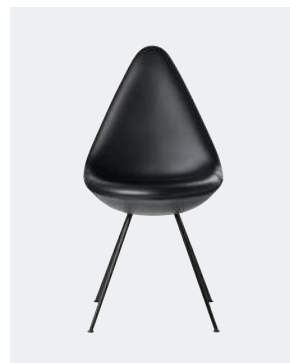

Model: 3110UB
Height: 88.5 cm / 34.8 in
Seat height: 46 cm / 18.1 in
Width: 45.5 cm / 17.9 in
Depth: 54.5 cm / 21.5 in

Available in additional heights

CHAIRS

CHINA CHAIR™

Design: Hans J. Wegner, 1944

The China Chair™ was designed by Hans J. Wegner in 1944. Inspired by the timeless aesthetic of ancient Chinese design in the 17th and 18th century, the China Chair epitomises his lifelong quest to understand the nature of wood and explore its possibilities. In his modern interpretation, he unfolds his talent as a wood craftsman and his flair for expressive and sculptural functionalism.

Shell/Base: Solid wood (cherry and black coloured ash).
Seat cushion: Upholstered in selected leather types.



Model: 4283
Height: 82 cm / 32.3 in
Seat height: 45 cm / 17.7 in
Armrest height: 68 cm / 26.8 in
Width: 55 cm / 21.7 in
Depth: 55 cm / 21.7 in

N01™

Design: nendo, 2018

The N01™ chair fuses Danish and Japanese design in nine layers of pressure moulded veneer and solid wood legs. Millimetre by millimetre, the design is an illustration of beauty and functionality.

Shell/Base: Mix of solid wood and veneer (beech, oak or black coloured oak).
Accessories: Seat cushion.



Model: N01
Height: 77 cm / 30.3 in
Seat height: 46.5 cm / 18.3 in
Armrest height: 66 cm / 26 in
Width: 62 cm / 24.4 in
Depth: 49 cm / 19.3 in



CHAIRS

N02™ RECYCLE

Design: nendo, 2019

The N02™ Recycle is a multi-use chair made from upcycled plastic household waste that can be recycled again. A crease in the chair's back is inspired by a folded piece of paper on the designer's studio table and provides extra support for the upper and lower back. Seven colour options are inspired by Scandinavian nature and, along with multiple base options, make N02 Recycle particularly applicable for work, meeting and dining arrangements.

Shell: Recycled plastic.

Base: Chromed or powder coated steel.

Accessories: Seat cushion, Felt glides, Linking device etc.

The EU Ecolabel is a label of environmental excellence that is awarded to products and services meeting high environmental standards throughout their life-cycle: from raw material extraction, to production, distribution and disposal.



Model: N02-10
Height: 81 cm / 31.9 in
Seat height: 46 cm / 18.1 in
Width: 54 cm / 21.3 in
Depth: 54 cm / 21.3 in
Features: Stackable

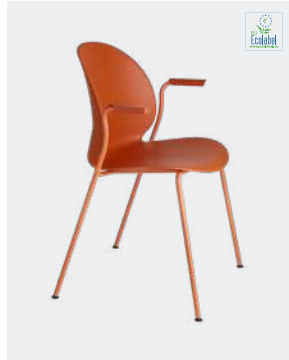

Model: N02-11
Height: 81 cm / 31.9 in
Seat height: 46 cm / 18.1 in
Armrest height: 67 cm / 26.4 in
Width: 61 cm / 24 in
Depth: 54 cm / 21.3 in
Features: Stackable



Model: N02-20
Height: 81 cm / 31.9 in
Seat height: 46 cm / 18.1 in
Width: 54 cm / 21.3 in
Depth: 53 cm / 20.9 in
Features: Stackable

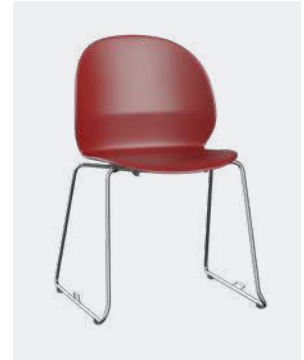

Model: N02-21
Height: 81 cm / 31.9 in
Seat height: 46 cm / 18.1 in
Width: 54 cm / 21.3 in
Depth: 53 cm / 20.9 in
Features: Stackable



Model: N02-30
Height: 77-90 cm / 30.3-35.4 in
Seat height: 42-55 cm / 16.5-21.6 in
Width: 62.5 cm / 24.6 in
Depth: 62.5 cm / 24.6 in



Model: N02-31
Height: 77-90 cm / 30.3-35.4 in
Seat height: 42-55 cm / 16.5-21.6 in
Armrest height: 63-76 cm / 24.8-30 in
Width: 62.5 cm / 24.6 in
Depth: 62.5 cm / 24.6 in



Model: N02-40
Height: 99.3 cm / 39.09 in
Seat height: 64 cm / 25.2 in
Width: 51.2 cm / 21.3 in
Depth: 51.8 cm / 20.39 in

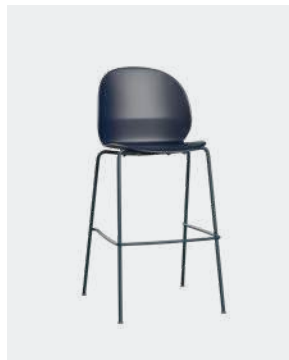

Model: N02-50
Height: 111.2 cm / 43.78 in
Seat height: 76 cm / 29.9 in
Width: 52.3 cm / 21.81 in
Depth: 56.5 cm / 22.24 in



CHAIRS

VICO DUO

Design: Vico Magistretti, 1997/2020

The Vico Duo is a stylish veneer stacking chair with simple, tight lines. Magistretti designed the original in 1997, sitting among his sketches in Fritz Hansen's design department. The chair is well suited for agile work spaces and hospitality.

Shell: Veneer (oak, walnut or black coloured ash). Available with front- and fully upholstered in a wide range of textiles and leather types.
 Base: Chromed and powder coated steel (black).
 Accessories: Seat cushion, Felt glides and transport dolly etc.



Model: VM110
 Height: 79 cm / 31.1 in
 Seat height: 46 cm / 18.1 in
 Width: 55 cm / 21.7 in
 Depth: 52 cm / 20.5 in
 Features: Stackable



Model: VM111
 Height: 79 cm / 31.1 in
 Seat height: 46 cm / 18.1 in
 Armrest height: 68 cm / 26.8 in
 Width: 60 cm / 23.6 in
 Depth: 52 cm / 20.5 in
 Features: Stackable



Model: VM112
 Height: 79.2 cm / 31.1 in
 Seat height: 46/18.1 in
 Width: 55 cm / 21.6 in
 Depth: 52 cm / 20.5 in
 Features: Stackable, linking device



Model: VM113
 Height: 79.2 cm / 31.18 in
 Seat height: 46 / 18.1 in
 Width: 60.4 cm / 23.78 in
 Depth: 51.8 cm / 20.39 in
 Features: Stackable, linking device



Model: VM114
 Height: 79.4 cm / 31.26 in
 Seat height: 46 cm / 18.1 in
 Width: 52.6 cm / 20.71 in
 Depth: 51.4 cm / 20.24 in
 Features: Stackable

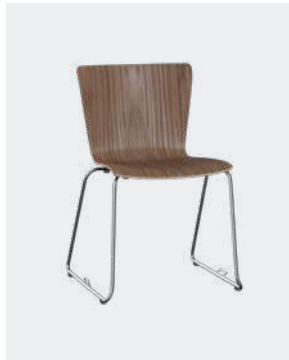

Model: VM115
 Height: 79.4 cm / 31.26 in
 Seat height: 46 cm / 18.1 in
 Width: 52.6 cm / 20.71 in
 Depth: 51.4 cm / 20.24 in
 Features: Stackable, linking device



Model: VM116
 Height: 97.6 cm / 38.43 in
 Seat height: 64 cm / 25 in
 Width: 54.9 cm / 21.61 in
 Depth: 51.4 cm / 20.24 in
 Features: Stackable



Model: VM118
 Height: 109.8 cm / 43.23 in
 Seat height: 76 cm / 30 in
 Width: 55.9 cm / 22.01 in
 Depth: 54.4 cm / 21.42 in
 Features: Stackable



CHAIRS

NAP™

Design: Kasper Salto, 2010

The iconic NAP™ chair features an elegant, curvaceous form. The contours of the Nylon shell adapt naturally to the shape of the human body and the textured waves make hours of sitting a superb experience – no matter the position. It features a high gloss back and a rippled matt front to emphasise the chair's dynamic design.

Shell: Plastic.

Base: Chromed, powder coated steel or veneer (oak).

Accessories: Seat cushion, Linking device.



Model: KS50
Height: 77 cm / 30.3 in
Seat height: 45 cm / 17.7 in
Width: 54 cm / 21.3 in
Depth: 51 cm / 20 in
Features: Stackable



Model: KS60
Height: 77 cm / 30.3 in
Seat height: 45 cm / 17.7 in
Armrest height: 64-67 cm / 25.2-26.4 in
Width: 62 cm / 24.4 in
Depth: 51 cm / 20 in
Features: Stackable



Model: KS58
Height: 97 cm / 38.2 in
Seat height: 64 cm / 25.2 in
Width: 56 cm / 22 in
Depth: 52 cm / 20.5 in



Model: KS68
Height: 97 cm / 38.2 in
Seat height: 64 cm / 25.2 in
Armrest height: 83-86 cm / 32.7-33.9 in
Width: 62 cm / 24.4 in
Depth: 52 cm / 20.5 in

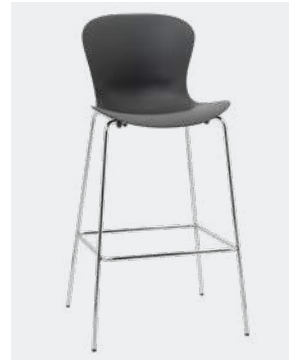

Model: KS59
Height: 109 cm / 43 in
Seat height: 76 cm / 30 in
Width: 56 cm / 22 in
Depth: 54 cm / 21.2 in



Model: KS69
Height: 109 cm / 43 in
Seat height: 76 cm / 30 in
Armrest height: 95-98 cm / 37.4-38.6 in
Width: 62 cm / 24.4 in
Depth: 54 cm / 21.2 in



Model: KS52
Height: 77 cm / 30.3 in
Seat height: 45 cm / 17.7 in
Width: 54 cm / 21.3 in
Depth: 51 cm / 20 in



Model: KS62
Height: 77 cm / 30.3 in
Seat height: 45 cm / 17.7 in
Armrest height: 64-67 cm / 25.2-26.4 in
Width: 62 cm / 24.4 in
Depth: 51 cm / 20 in

Available in additional height (chromed steel)

CHAIRS

OXFORD™

Design: Arne Jacobsen, 1965

The Oxford™ chair was handcrafted for the professors at St Catherine's College in Oxford and designed by Arne Jacobsen. A symbol of prestige and status, the high back and smooth, curved veneer form were crafted to invoke a sense of space and privacy. The design evolved over time into today's Oxford™.

Shell: Fully upholstered in textile or leather.
 Base: Satin polished aluminum, chrome (five-star base only) and powder-coated steel/aluminium.
 Options: Automatic return and armpads etc.



Model: 3141T
 Height: 89 cm / 35 in
 Seat height: 46 cm / 18.1 in
 Width: 50 cm / 19.6 in
 Depth: 61 cm / 24 in



Model: 3171T
 Height: 89 cm / 35 in
 Seat height: 46 cm / 18.1 in
 Width: 62 cm / 24.4 in
 Depth: 61 cm / 24 in



Model: 3191T
 Height: 82-96 cm / 32.2-37.7 in
 Seat height: 37-51 cm / 14.5-20 in
 Width: 62 cm / 24.4 in
 Depth: 58 cm / 22.8 in



Model: 3171W
 Height: 89 cm / 35 in
 Seat height: 46 cm / 18.1 in
 Width: 62 cm / 24.4 in
 Depth: 61 cm / 24 in



Model: 3191W
 Height: 87-101 cm / 34.2 - 39.7 in
 Seat height: 42-56 cm / 16.5-20 in
 Width: 62 cm / 24.4 in
 Depth: 58 cm / 22.8 in



Model: 3241T
 Height: 89 cm / 35 in
 Seat height: 46 cm / 18.1 in
 Armrest height: 68 cm / 26.7 in
 Width: 62 cm / 24.4 in
 Depth: 61 cm / 24 in



Model: 3271T
 Height: 89 cm / 35 in
 Seat height: 46 cm / 18.1 in
 Armrest height: 68 cm / 26.7 in
 Width: 62 cm / 24.4 in
 Depth: 61 cm / 24 in



Model: 3291T
 Height: 82-96 cm / 32.2-37.7 in
 Seat height: 37-51 cm / 14.5-20 in
 Armrest height: 59-73 cm / 23.2-28.7 in
 Width: 62 cm / 24.4 in
 Depth: 58 cm / 22.8 in



Model: 3271W
 Height: 89 cm / 35 in
 Seat height: 46 cm / 18.1 in
 Armrest height: 68 cm / 26.7 in
 Width: 62 cm / 24.4 in
 Depth: 61 cm / 24 in



Model: 3291W
 Height: 87-101 cm / 34.2-30.7 in
 Seat height: 42-56 cm / 16.5-20 in
 Armrest height: 64-78 cm / 25.1-30.7 in
 Width: 62 cm / 24.4 in
 Depth: 58 cm / 22.8 in



Model: 3143T
 Height: 102 cm / 40.1 in
 Seat height: 46 cm / 18.1 in
 Width: 50 cm / 19.6 in
 Depth: 63 cm / 24.8 in



Model: 3173T
 Height: 102 cm / 40.1 in
 Seat height: 46 cm / 18.1 in
 Width: 62 cm / 24.4 in
 Depth: 63 cm / 24.8 in

CHAIRS



Model: 3193T
 Height: 95-109 cm / 37.4-42.9 in
 Seat height: 37-51 cm / 14.5-20 in
 Width: 62 cm / 24.4 in
 Depth: 60 cm / 23.6 in



Model: 3173W
 Height: 102 cm / 40.1 in
 Seat height: 46 cm / 18.1 in
 Width: 62 cm / 24.4 in
 Depth: 63 cm / 24.8 in



Model: 3193W
 Height: 100-114 cm / 39.3-44.8 in
 Seat height: 42-56 cm / 16.5-22 in
 Width: 62 cm / 24.4 in
 Depth: 60 cm / 23.6 in



Model: 3243T
 Height: 102 cm / 40.1 in
 Seat height: 46 cm / 18.1 in
 Armrest height: 68 cm / 26.7 in
 Width: 62 cm / 24.4 in
 Depth: 63 cm / 24.8 in



Model: 3273T
 Height: 102 cm / 40.1 in
 Seat height: 46 cm / 18.1 in
 Armrest height: 68 cm / 26.7 in
 Width: 62 cm / 24.4 in
 Depth: 63 cm / 24.8 in



Model: 3293T
 Height: 95-109 cm / 37.4-42.9 in
 Seat height: 37-51 cm / 14.5-20 in
 Armrest height: 59-73 cm / 23.2-28.7 in
 Width: 62 cm / 24.4 in
 Depth: 60 cm / 23.5 in

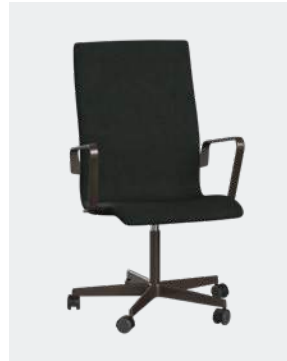

Model: 3273W
 Height: 102 cm / 40.1 in
 Seat height: 46 cm / 18.1 in
 Armrest height: 68 cm / 26.7 in
 Width: 62 cm / 24.4 in
 Depth: 63 cm / 24.8 in



Model: 3293W
 Height: 100-114 cm / 39.3-44.8 in
 Seat height: 42-56 cm / 16.5-22 in
 Armrest height: 64-78 cm / 25.1-30.7 in
 Width: 62 cm / 24.4 in
 Depth: 60 cm / 23.6 in

LITTLE GIRAFFE™

Design: Arne Jacobsen, 1959

The Giraffe chair was designed by Arne Jacobsen in 1959, specifically for the restaurant at the SAS Royal Hotel in Copenhagen. Its high back and padded armrests make for a cosy and comfortable seat. The Little Giraffe™ chair is an evolution of its iconic predecessor – a striking rendition suitable for hospitality, meeting rooms or dining spaces.

Shell: Fully upholstered in textile or leather (fixed or replaceable cover).
Base: Chromed or powder coated steel (select models) and polished or black powder coated aluminium (select models).



Model: 3201 / 3201R
 Height: 89.4 cm / 35.2 in
 Seat height: 46 cm / 18.1 in
 Armrest height: 65.5 cm / 25.7 in
 Width: 64 cm / 25.1 in
 Depth: 61 cm / 24 in



Model: 3211 / 3211R
 Height: 85-96 cm / 33.4-37.7 in
 Seat height: 43-54 cm / 16.9-21.2 in
 Armrest height: 62.5-73.5 cm / 24.6-28.9 in
 Width: 64 cm / 25.1 in
 Depth: 61 cm / 24 in

CHAIRS

PK8™

Design: Poul Kjærholm, 1978/2007

For many years, the PK8™ existed only as a prototype in the home of Hanne Kjærholm, the wife of Poul Kjærholm. Today, it's widely recognised as a striking execution of Scandinavian craftsmanship. Its unique three-legged form and sinuous curves give it an expression all its own.

Shell: Plastic (black or white) with front upholstery in leather.
Base: Anodised satin brushed aluminium.



Model: PK8
Height: 77 cm / 30.3 in
Seat height: 44 cm / 17.3 in
Width: 59 cm / 23.2 in
Depth: 51 cm / 20 in

PK9™

Design: Poul Kjærholm, 1960

The PK9's unique shape is characterised by three pieces of satin-brushed stainless spring steel that act as a column, carrying the leather seating element. Poul Kjærholm was inspired by a sand imprint of his wife's behind from a day at the beach. Later, during the design process, Hanne Kjærholm sat in boxes of clay to find the most optimal and comfortable solution.

Shell: Fully upholstered in leather.
Base: Satin brushed stainless spring steel.



Model: PK9
Height: 77 cm / 30.3 in
Seat height: 43 cm / 16.9 in
Width: 58 cm / 22.8 in
Depth: 58 cm / 22.8 in

PK11™

Design: Poul Kjærholm, 1957

Characterised by its three-legged satin brushed stainless steel frame, PK11™ strikes the perfect balance of curves and bold angles. Designed by Poul Kjærholm in 1957, it is a complex yet elegant chair, created as a companion to the PK51™ worktable.

Shell: Armrest in veneer (ash) with a seat upholstered in leather.
Base: Satin brushed stainless steel.



Model: PK11
Height: 69 cm / 27.2 in
Seat height: 43-44 cm / 17-17.3 in
Width: 64 cm / 25.2 in
Depth: 44 cm / 17.3 in



STOOLS

PK33™

Design: Poul Kjærholm, 1959

The iconic PK33™ epitomises Poul Kjærholm's use of assembly techniques, his exploration of materials and his simplification of structure into a type-form. The three-legged matt chromed spring steel stool borrows elements from his other designs, while still maintaining its own unique expression.

Seat: Canvas or leather.
Base: Matt chromed spring steel.



Model: PK33
Height: 34 cm / 13.4 in
Width: 53 cm / 20.9 in
Depth: 53 cm / 20.9 in

PK91™

Design: Poul Kjærholm, 1961

The PK91™, designed by Poul Kjærholm, is an homage to the designer's mentor, Kaare Klint, who made a folding chair in wood in 1930. This folding stool is unmistakably a Kjærholm classic.

Seat: Canvas or leather.
Base: Satin brushed stainless steel.



Model: PK91
Height: 41 cm / 16.1 in
Width: 59 cm / 23.2 in
Depth: 45 cm / 17.7 in

DOT™

Design: Arne Jacobsen, 1955

The Dot™ stool is beautiful, simple seating that can be used as core or extra seating in the office, or at home. Modern, minimal and quiet, this sophisticated design was used by Arne Jacobsen in multiple, important projects.

Seat: Leather (Wild in walnut / Intense in black / Buffed in Lava).
Base: Chromed or powder coated (matt black) steel.



Model: 840100 / 840105
Height: 46 cm / 18.1 in
Width: 34 cm / 13.4 in
Depth: 34 cm / 13.4 in
Note: Accessories assortment

HIGH DOT™

Design: Arne Jacobsen, 1955

The High Dot™ stool is beautiful, simple high seating for counters, bars or high office tables. Modern, minimal and quiet, this sophisticated design by Arne Jacobsen is timeless and practical.

Seat: Leather (Wild in walnut / Intense in black / Buffed in Lava).
Base: Chromed or powder coated (matt black) steel.



Model: 840106 / 840107
Height: 65 cm / 25.6 in
Width: 44 cm / 17.3 in
Depth: 44 cm / 17.3 in
Note: Accessories assortment

LOUNGE

SERIES 3300™

Design: Arne Jacobsen, 1956

The Series 3300™ was designed by Arne Jacobsen for the SAS Air Terminal connected to the SAS Royal Hotel. The series exudes Jacobsen's unfailing sense of line and proportion and is proof of his ability to design everlasting classics. The Series 3300™ forms an elegant contrast to the organic shapes of the Egg and Swan chairs, also designed especially for the Royal Hotel.

Shell: Fully upholstered in textile or leather.
Base: Chromed steel.



Model: 3300
Height: 72 cm / 28.4 in
Seat height: 36 cm / 14.2 in
Armrest height: 49-54 cm / 19.3-21.3 in
Width: 73 cm / 28.7 in
Depth: 79 cm / 31.1 in
Features: 2- and 3-seater sofa

SWAN™

Design: Arne Jacobsen, 1958

The beautiful Swan™ chair was designed by Arne Jacobsen in 1958 for the lobby and lounge areas of the SAS Royal Hotel in Copenhagen. The design contains no straight lines, making it look organic and soft despite its simplicity and strong architectural appeal.

Shell: Fully upholstered in textile or leather.
Base: Aluminium/Satin polished steel/Powder coated steel.



Model: 3320
Height: 77 cm / 30.3 in
Seat height: 40 cm / 15.8 in
Armrest height: 58 cm / 22.8 in
Width: 74 cm / 33.9 in
Depth: 68 cm / 26.8 in
Features: Automatic return, 2-seater sofa

POT™

Design: Arne Jacobsen, 1959

Arne Jacobsen created the Pot™ in 1959 for the SAS Royal Hotel in Copenhagen. Years later, the Pot was relaunched with a fresh take on Jacobsen's signature lounge chair, revitalised for the modern interior. Retaining the striking shape of its predecessor, the modern rendition meets today's demands through improved comfort and quality.

Shell: Fully upholstered in textile or leather.
Base: Chromed or dark brown powder coated steel.



Model: 3318
Height: 70 cm / 27.5 in
Seat height: 42.7 cm / 16.8 in
Width: 75.5 cm / 29.7 in
Depth: 60 cm / 23.6 in



LOUNGE

EGG™

Design: Arne Jacobsen, 1958

The Egg™ chair by Arne Jacobsen is an everlasting Danish design masterpiece. Like a sculptor, Jacobsen strived to shape the shell's perfect form by experimenting with wire and plaster in his garage. Today, it is recognised worldwide as one of the triumphs of Jacobsen's legendary career and a monumental achievement in Scandinavian craftsmanship.

Shell: Fully upholstered in textile or leather.

Base: Aluminium/Satin polished steel/Powder coated steel.



Model: 3316
Height: 107 cm / 42.1 in
Seat height: 37 cm / 14.6 in
Armrest height: 58 cm / 22.8 in
Width: 86 cm / 33.9 in
Depth: 79-95 cm / 31.1-37.4 in
Features: Automatic return

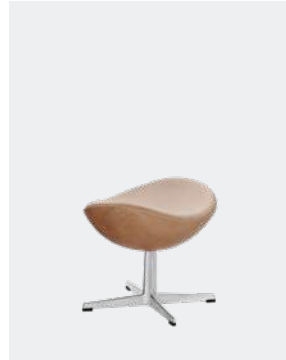

Model: 3127
Height: 37 cm / 14.6 in
Width: 56 cm / 22 in
Depth: 40 cm / 15.7 in

OKSEN™

Design: Arne Jacobsen, 1966

The Oksen easy chair takes on a sharp, powerful expression, dominating a room like nothing else. Arne Jacobsen shocked design connoisseurs all over the world when he first introduced Oksen™ in 1966 – after no less than five years of design experimentation. In contrast to many of his earlier pieces characterised by rounded, organic shapes, Oksen is the largest and most controversial chair Arne Jacobsen ever designed.

Shell: Fully upholstered in leather.

Base: Satin polished or black powder coated aluminium.



Model: 4201
Height: 115 cm / 45.2 in
Seat height: 43 cm / 17 in
Armrest height: 58 cm / 22.8 in
Width: 101 cm / 39.8 in
Depth: 87 cm / 34.3 in
Features: Automatic return

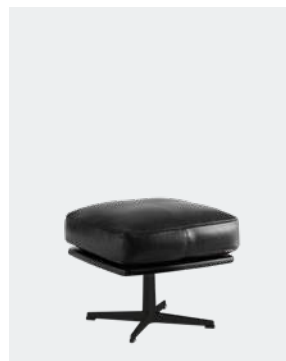

Model: 4210
Height: 40 cm / 15.7 in
Width: 52 cm / 20.4 in
Depth: 52 cm / 20.4 in

LOUNGE

RO™

Design: Jaime Hayon, 2013

The Ro™ lounge chair is aptly named after the Danish word for 'tranquillity'. Designed by Jaime Hayon, the easy chair creates space for relaxation and reflection, enticing you to immerse in its curves and take a moment for yourself. The four-legged base is made of brushed aluminium or solid oak with a clear lacquer finish.

Shell: Fully upholstered in textile (mix two textiles for shell and cushions) or leather.

Base: Brushed aluminium or solid wood (oak).



Model: JH1
 Height: 113 cm / 44.5 in
 Seat height: 43 cm / 17 in
 Armrest height: 61 cm / 24 in
 Width: 80 cm / 31.5 in
 Depth: 97 cm / 38.2 in
 Features: 2-seater sofa



Model: JH2
 Height: 113 cm / 44.5 in
 Seat height: 43 cm / 17 in
 Armrest height: 61 cm / 24 in
 Width: 80 cm / 31.5 in
 Depth: 97 cm / 38.2 in
 Features: 2-seater sofa



Model: JH11
 Height: 40 cm / 15.7 in
 Width: 58 cm / 22.8 in
 Depth: 49 cm / 19.3 in



Model: JH12
 Height: 40 cm / 15.7 in
 Width: 58 cm / 22.8 in
 Depth: 49 cm / 19.3 in

FRI™

Design: Jaime Hayon, 2015

The Fri™ easy chair adds a striking, sophisticated expression to any interior. Designed by Spanish designer Jaime Hayon, the chair has a soft, sculptured form that is as pleasing to the body as it is to the eye.

Shell: Fully upholstered in textile or leather.

Base: Brushed aluminium or solid wood (oak).



Model: JH4
 Height: 90.5 cm / 35.6 in
 Seat height: 43 cm / 17 in
 Armrest height: 58.5 cm / 23 in
 Width: 80 cm / 31.5 in
 Depth: 88 cm / 34.6 in
 Features: Non-glued upholstery



Model: JH5
 Height: 90.5 cm / 35.6 in
 Seat height: 43 cm / 17 in
 Armrest height: 58.5 cm / 23 in
 Width: 80 cm / 31.5 in
 Depth: 88 cm / 34.6 in
 Features: Non-glued upholstery



Model: JH14
 Height: 40 cm / 15.7 in
 Width: 58 cm / 22.8 in
 Depth: 49 cm / 19.3 in



Model: JH15
 Height: 40 cm / 15.7 in
 Width: 58 cm / 22.8 in
 Depth: 49 cm / 19.3 in

LOUNGE

VIA57™

Design: Bjarke Ingels in collaboration with KiBiSi, 2016

The VIA57™ easy chair was designed as part of a collaboration between Bjarke Ingels and Danish design group KiBiSi. The collaboration celebrates the completion of Bjarke Ingels Group's first New York City project – the VIA57 WEST building – offering design aficionados around the world the opportunity to experience a piece of the Manhattan skyline in their own homes.

Shell: Fully upholstered in textile.
Base: Solid wood (oak).



Model: BI01
Height: 78 cm / 30.7 in
Seat height: 42 cm / 16.4 in
Width: 93 cm / 36.5 in
Depth: 91 cm / 35.8 in

FRED™

Design: Jaime Hayon, 2019

Elegant from every angle, the Fred™ lounge chair is a nod to calm and comfortable living. Designed by Jamie Hayon, the chair features a low, open silhouette and a sculpted wooden frame, crafted and assembled with care by hand. Wide, flat armrests and upright seating support the neck and arms – ideal for long periods of socialising or reading.

Cushions: Upholstered in textile or leather.
Base: Solid wood (black painted ash, walnut stained oak, clear lacquered oak or oiled oak).



Model: JH97
Height: 85.2 cm / 33.5 in
Seat height: 41 cm / 16.1 in
Armrest height: 55.6 cm / 21.8 in
Width: 77.4 cm / 30.4 in
Depth: 80.5 cm / 31.7 in

LET™

Design: Sebastian Herkner, 2020

The Let™ lounge chair is a low lounge chair with a fine silhouette and sculptural design by Sebastian Herkner for Fritz Hansen. The seat cushion visually 'floats' on the frame, surrounded by an enveloping backrest. Let embodies the German designer's skills and aesthetic, with Fritz Hansen's expert craftsmanship. It is designed for a wide variety of expressions and interior styles.

Shell: Fully upholstered seat and backrest.
Base: Solid wood (lacquered oak, lacquered ash or black coloured ash), chromed or powder coated steel.



Model: SH200
Height: 80 cm / 31.4 in
Seat height: 42 cm / 16.5 in
Width: 56.5 cm / 22.2 in
Depth: 50 cm / 19.7 in



Model: SH210
Height: 80 cm / 31.4 in
Seat height: 42 cm / 16.5 in
Width: 56.5 cm / 22.2 in
Depth: 50 cm / 19.7 in

LOUNGE

PK20™

Design: Poul Kjærholm, 1968

The PK20™ is a laidback and elegant easy chair, designed by Poul Kjærholm. Handcrafted in both wicker and leather, the chair features soft leather upholstery and a reclining headrest, resting on a flexible matt chromed spring steel frame. Over the years, the PK20 has become a Poul Kjærholm classic – as well as a permanent fixture at the Victoria and Albert Museum in London.

Shell: Leather (w. headrest) or wicker.
Base: Matt chromed spring steel.



Model: PK20
Height: 84 cm / 33.1 in
Seat height: 37 cm / 14.6 in
Width: 80 cm / 31.5 in
Depth: 71 cm / 28 in



Model: PK20
Height: 89 cm / 35 in
Seat height: 37 cm / 14.6 in
Width: 80 cm / 31.5 in
Depth: 71 cm / 28 in

PK22™

Design: Poul Kjærholm, 1956

The PK22™ has the subtle silhouette that has become a genuine design classic. The iconic chair exemplifies Poul Kjærholm's vision and quest for the ideal form and dimension. It remains a fundamentally modern chair for design enthusiasts today.

Shell: Canvas, leather or wicker.
Base: Satin brushed stainless spring steel.



Model: PK22
Height: 71 cm / 28 in
Seat height: 35 cm / 13.8 in
Width: 63 cm / 24.8 in
Depth: 63 cm / 24.8 in

PK25™

Design: Poul Kjærholm, 1951

The PK25™ was designed by Poul Kjærholm for his final graduation project at the School of Arts and Crafts in 1952. Also known as the 'Element' chair, the PK25 is a striking example of Kjærholm's eagerness to transform common, industrial materials into striking works of art. Kjærholm was determined to reduce the chair to a single piece of each material, resulting in its overarching hallmark: the continual steel frame that bends through the form without interruption.

Shell: Flag halyard (natural or black)
Base: Matt chromed spring steel.



Model: PK25
Height: 75 cm / 29.5 in
Seat height: 40 cm / 15.7 in
Width: 69 cm / 27.2 in
Depth: 73 cm / 28.7 in

LOUNGE

PK24™

Design: Poul Kjærholm, 1965

The PK24™ chaise longue chair stands out as perhaps the most recognisable chair in Fritz Hansen's Poul Kjærholm's collection. Inspired by the Rococo period and the French chaise longue, Kjærholm used steel to support a curvy, flowing form. He labelled it the 'Hammock Chair' to stress that it functions by suspending the body between two points.

Shell: Leather or wicker.

Base: Satin brushed stainless steel.



Model: PK24
Height: 85 cm / 34.3 in
Seat height: 14 cm / 5.5 in
Width: 67 cm / 26.4 in
Depth: 155 cm / 61 in
Features: Leather upholstered headrest

PK31™

Design: Poul Kjærholm, 1958

The PK31™ chair and sofa series is a prime example of Poul Kjærholm's ability to work with exquisite materials and minimalism. In the search for the ideal form, Kjærholm created the PK31 – a fusion of elegance, luxury and comfort. The PK31 series is available as an armchair and a 2- or 3-seater sofa and features a matt chromed spring steel frame.

Shell: Fully upholstered in leather.

Base: Matt chromed spring steel.



Model: PK31
Height: 76 cm / 29.9 in
Seat height: 38 cm / 15 in
Armrest height: 48 cm / 18.9 in
Width: 76 cm / 29.9 in
Depth: 76 cm / 29.9 in
Features: 2- and 3-seater sofa

PK80™

Design: Poul Kjærholm, 1957

The PK80™ Daybed is the embodiment of Poul Kjærholm's talent for refining historical models and distilling design down to its very essence. The daybed draws inspiration from a couch designed by Mies van der Rohe and Lilly Reich in 1930. It can be found today in the Museum of Modern Art and around the world as a celebrated illustration of craftsmanship and modern design.

Shell: Canvas or leather.

Base: Satin brushed stainless steel.



Model: PK80
Height: 30 cm / 11.8 in
Width: 190 cm / 74.8 in
Depth: 80 cm / 31.5 in

PK81™

Design: Poul Kjærholm, 1959

PK81™ is a square version of Poul Kjærholm's classic daybed, made to furnish the public area of the new Tårnby town hall by Halldor Gunløgsson and Jørn Nielsen. Today, it graces powerful spaces around the world, including the Museum of Modern Art in New York City.

Shell: Leather.

Base: Satin brushed stainless steel.



Model: PK81
Height: 30 cm / 11.8 in
Width: 140 cm / 55.1 in
Depth: 140 cm / 55.1 in

SOFAS

SWAN SOFA™

Design: Arne Jacobsen, 1958

The Swan Sofa™ was designed by Arne Jacobsen in 1958 for the SAS Royal Hotel in Copenhagen and reintroduced to Fritz Hansen's collection in 2000. The design contains no straight lines, making it organic and soft to the eye despite its simplicity and strong architectural appeal.

Shell: Fully upholstered in textile or leather.
Base: Satin polished aluminium.



Model: 3321
Height: 79 cm / 31.1 in
Seat height: 40 cm / 15.8 in
Armrest height: 58 cm / 22.8 in
Width: 144 cm / 56.7 in
Depth: 74 cm / 29.1 in
Features: Lounge chair

PK26™

Design: Poul Kjærholm, 1956

The PK26™ is a striking wall-mounted sofa in flat steel with leather-covered back and seat, designed by Poul Kjærholm. The sofa appears to float mid-air with an extraordinary design that is beautiful from every angle.

Shell: Fully upholstered in leather.
Base: Matt chromed spring steel.



Model: PK26
Height: 76 cm / 29.9 in
Seat height: 36 cm / 14.2 in
Width: 152 cm / 59.8 in
Depth: 76 cm / 29.9 in
Features: Extendable

PK31™

Design: Poul Kjærholm, 1958

The PK31™ chair and sofa series is a prime example of Poul Kjærholm's ability to work with exquisite materials and minimalism. In the search for the ideal form, Kjærholm created the PK31 – a fusion of elegance, luxury and comfort. The PK31 series is available as an armchair and a 2- or 3-seater sofa and features a matt chromed spring steel frame.

Shell: Fully upholstered in leather.
Base: Matt chromed spring steel.



Model: PK31/2
Height: 76 cm / 29.9 in
Seat height: 38 cm / 15 in
Armrest height: 48 cm / 18.9 in
Width: 137 cm / 54 in
Depth: 76 cm / 29.9 in
Features: Lounge chair



Model: PK31/3
Height: 76 cm / 29.9 in
Seat height: 38 cm / 15 in
Armrest height: 48 cm / 18.9 in
Width: 198 cm / 78 in
Depth: 76 cm / 29.9 in
Features: Extension units, Lounge chair

SOFAS

LISSONI SOFA™

Design: Piero Lissoni, 2006

The Lissoni Sofa™ is a sophisticated, modern sofa that adds a healthy dose of comfort and luxury to everyday life. Characterized by clean lines and flawless attention to detail, this sofa by Piero Lissoni has a remarkably pronounced appearance that elevates and adds character to any room.

Shell: Fully upholstered in textile or leather.

Base: Matt polished stainless steel/ Powder coated steel.



Model: PL112
Height: 75 cm / 29.5 in
Seat height: 41 cm / 16.1 in
Armrest height: 53 cm / 20.7 in
Width: 198 cm / 77.9 in
Depth: 92 cm / 36.2 in



Model: PL113
Height: 75 cm / 29.5 in
Seat height: 41 cm / 16.1 in
Armrest height: 53 cm / 20.7 in
Width: 288 cm / 113.4 in
Depth: 92 cm / 36.2 in



Model: PL112S
Height: 75 cm / 29.5 in
Seat height: 41 cm / 16.1 in
Armrest height: 53 cm / 20.7 in
Width: 168 cm / 66.14 in
Depth: 92 cm / 36.2 in



Model: PL113S
Height: 75 cm / 29.5 in
Seat height: 41 cm / 16.1 in
Armrest height: 53 cm / 20.7 in
Width: 243 cm / 88.2 in
Depth: 92 cm / 36.2 in

SOFAS

FAVN™

Design: Jaime Hayon, 2011

Derived from the Danish term for 'embrace', the Favn™ sofa is a design collaboration between designer Jaime Hayon and Fritz Hansen. Its open and rounded curves are intended to appeal and invite – the perfect setting for relaxation, work and everything in-between.

Shell: Fully upholstered in textile (mix three textiles for shell, cushions and decorative cushions)

Base: Brushed aluminium legs.



Model: JH3
Height: 88 cm / 34.6 in
Seat height: 42 cm / 16.5 in
Armrest height: 60 cm / 23.6 in
Width: 221 cm / 87 in
Depth: 93 cm / 36.6 in
Features: Buy additional decorative cushions

SERIES 3300™

Design: Arne Jacobsen, 1956

The Series 3300™ was designed by Arne Jacobsen for the SAS Air Terminal connected to the SAS Royal Hotel. The series exudes Jacobsen's unflinching sense of line and proportion and is proof of his ability to design everlasting classics. The Series 3300™ forms an elegant contrast to the organic shapes of the Egg and Swan chairs, also designed especially for the Royal Hotel.

Shell: Fully upholstered in textile or leather.

Base: Chromed steel.



Model: 3302
Height: 72 cm / 28.4 in
Seat height: 36 cm / 14.2 in
Armrest height: 49-54 cm / 19.3-21.3 in
Width: 126 cm / 49.6 in
Depth: 79 cm / 31.1 in
Features: Lounge chair



Model: 3303
Height: 72 cm / 28.4 in
Seat height: 36 cm / 14.2 in
Armrest height: 49-54 cm / 19.3-21.3 in
Width: 182 cm / 71.7 in
Depth: 79 cm / 31.1 in
Features: Extension units, lounge chair

SOFAS

ALPHABET SOFA™ SERIES

Design: Piero Lissoni, 2008

The Alphabet™ Sofa Series is a modular sofa system with units that can be combined in a variety of ways. The fully upholstered seat, back and armrest units come in a wide range of textiles, which can be removed for cleaning or replacement. You can choose to include a piping along the edges on both seat, back and armrests.

Shell: Fully upholstered in textile.

Accessories: Loose decorative cushions.



Model: PL240-4
 Height: 70 cm / 27.6 in
 Seat height: 40 cm / 15.7 in
 Width: 240 cm / 94.5 in
 Depth: 120 cm / 47.2 in

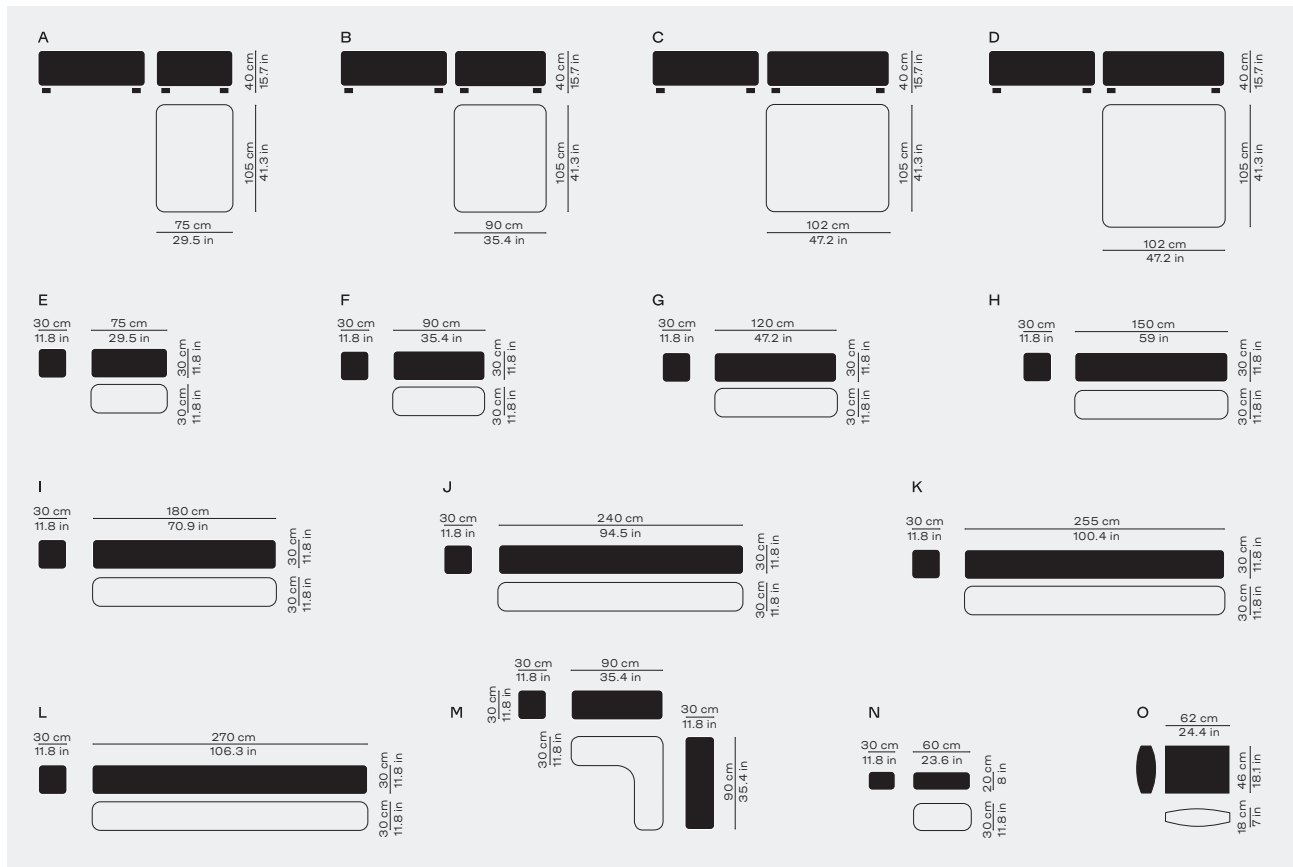

- A Seat unit
- B Seat unit
- C Seat unit
- D Seat unit
- E Back unit
- F Back unit
- G Back unit
- H Back unit
- I Back unit
- J Back unit
- K Back unit
- L Back unit
- M Back corner unit
- N Armrest unit
- O Decorative cushion

SOFAS

RO™ SOFA

Design: Jaime Hayon, 2017

The two-seater Ro sofa showcases the curvy form and playful expression that serve as the bedrock of Jaime Hayon's renowned design philosophy. Here, softness is expressed in an intimate yet spacious social setting for two.

Shell: Fully upholstered in textile (mix two textiles for shell and cushions)
Base: Brushed aluminium or solid wood (oak).



Model: JH110
 Height: 115.5 cm / 45.5 in
 Seat height: 42.5 cm / 16.7 in
 Armrest height: 62.5 cm / 24.6 in
 Width: 150 cm / 59.1 in
 Depth: 97 cm / 38.2 in
 Features: Lounge chair



Model: JH120
 Height: 115.5 cm / 45.5 in
 Seat height: 42.5 cm / 16.7 in
 Armrest height: 62.5 cm / 24.6 in
 Width: 150 cm / 59.1 in
 Depth: 97 cm / 38.2 in
 Features: Lounge chair

LUNE™

Design: Jaime Hayon, 2017

The sculptural, curvaceous Lune™ sofa is characteristic of designer Jaime Hayon and sits at the intersection of clean Nordic aesthetics and southern elegance. Lune is a functional, modular sofa that offers a myriad of possibilities: from a straight two-seater to larger L-shapes with chaise longue options. The result: a flexible sofa that is not only cosy and comfortable but also inherently beautiful from every angle.

Shell: Fully upholstered in textile or leather.
Base: Brushed aluminium, oak or black coloured oak.



Model: JH200
 Height: 81.5 cm / 32 in
 Seat height: 40.5 cm / 15.9 in
 Armrest height: 60.5 cm / 23.8 in
 Width: 155 cm / 61.1 in
 Depth: 93.5 cm / 36.8 in

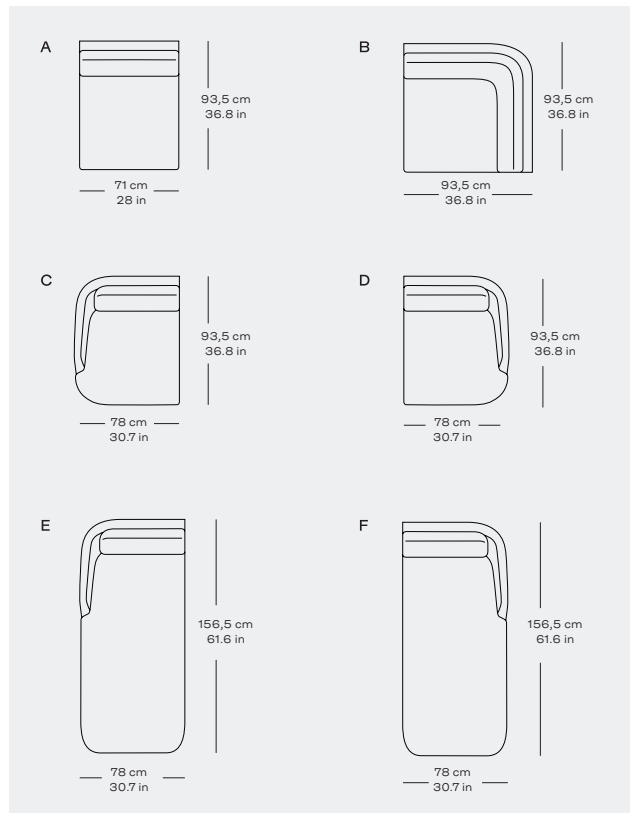

A Central unit
 B Corner unit
 C Arm unit left
 D Arm unit right
 E Chaise longue unit left
 F Chaise longue unit right

SOFAS

PLENUM™

Design: Jaime Hayon, 2018

Plenum™ pays homage to the modern workspace – the perfect setting for collaboration, concentration or relaxation. Designed by Jamie Hayon, the curved high-back sofa system consists of one, two or three-seater units and features a range of added functionalities such as power plugs, USB ports and mounted or separate tables.

Sofa shell: Fully upholstered in textile.

Table top: Light grey laminate.

Base: Black powder coated steel.



Model: JH1001
Height: 143.4 cm / 56.4 in
Seat height: 46 cm / 18.1 in
Armrest height: 69.4 cm / 27.3 in
Width: 110.5 cm / 43.5 in
Depth: 82.1 cm / 32.3 in
Features: Power unit incl. USB ports*



Model: JH70
Height: 68.1 cm / 26.8 in
Diameter: 30 cm / 11.8 in
Note: To be mounted on sofa units upon order



Model: JH1002
Height: 143.4 cm / 56.4 in
Seat height: 46 cm / 18.1 in
Armrest height: 69.4 cm / 27.3 in
Width: 173.5 cm / 68.3 in
Depth: 82.1 cm / 32.3 in
Features: Power unit incl. USB ports*



Model: JH75
Height: 51.7 cm / 20.3 in
Length: 126 cm / 49.6 in
Width: 75.9 cm / 29.8 in



Model: JH1003
Height: 143.4 cm / 56.4 in
Seat height: 46 cm / 18.1 in
Armrest height: 69.4 cm / 27.3 in
Width: 236.5 cm / 91.1 in
Depth: 82.1 cm / 32.3 in
Features: Power unit incl. USB ports*



Model: JH80
Height: 72.5 cm / 28.5 in
Length: 126 cm / 49.6 in
Width: 75.9 cm / 29.8 in

* Available in select countries.

COFFEE TABLES

COFFEE TABLE SERIES

Design: Piet Hein/Arne Jacobsen, 1968

Fritz Hansen offers a wide range of coffee tables assembled from legendary design components, in keeping with the Table Series design DNA. Elegant coffee tables can be created to complement any interior design.

Table top: Laminate or veneer (walnut).

Base: Satin polished aluminium/chromed steel/ powder coated steel.



Model: A202 (Super-Circular™)
Height: 47 cm / 18.5 in
Length: 75 cm / 29.5 in
Width: 75 cm / 29.5 in



Model: A203 (Super-Circular™)
Height: 47 cm / 18.5 in
Length: 100 cm / 39.4 in
Width: 100 cm / 39.4 in



Model: A222 (Circular)
Height: 47 cm / 18.5 in
Diameter: 75 cm / 29.5 in



Model: A223 (Circular)
Height: 47 cm / 18.5 in
Diameter: 90 cm / 35.4 in

LITTLE FRIEND™

Design: Kasper Salto, 2005

Little Friend™ by Kasper Salto is a flexible, multifunctional and portable solution to the challenges of modern minimalistic working and living. It is perfect for a laptop as well as morning coffee.

Table top: Compact laminate (black or white) or veneer (oak or walnut).
Base: Chromed steel/Polished aluminium or lacquered steel.



Model: KS11
Height: 50-73 cm / 19.7-28.7 in
Diameter: 45 cm / 17.7 in
Features: Height adjustable



Model: KS12
Height: 60 cm / 23.6 in
Diameter: 45 cm / 17.7 in

TRAY TABLE

Design: Fritz Hansen, 1958

The Tray Table is a side table and a folding tray table. It was originally created for the staff of Fritz Hansen in 1958, but others quickly admired its organic shape and tapered legs and suggested the table be put into production.

Table top: Veneer (oiled oak or black lacquered oak).
Base: Solid wood (oiled oak or black lacquered oak).



Model: 840120 / 840121
Height: 42 cm / 16.5 in
Diameter: 45 cm / 17.7 in
Features: Foldable
Note: Accessories assortment



Model: 840122
Height: 39 cm / 15.4 in
Diameter: 60 cm / 23.6 in
Features: Foldable
Note: Accessories assortment

STUB

Design: Mette Schelde, 2020

Wood and glass merge smoothly within this unique table design. Inspired by a wooden 'stump', Stub (means 'stump' in Danish) has a clear glass circle that floats around the veneer base.

Table top: Veneer (oiled oak or black lacquered oak).
Base: Solid wood (oiled oak or black lacquered oak).



Model: MS11
Height: 44.5 cm / 17.52 in
Diameter: 49 cm / 19.29 in

JOIN™

Design: Fritz Hansen, 2014

The Join™ series was born out of a desire to create a flexible, light coffee table that could bring people and furniture together in one seamless union. The series has a subtle, understated expression and comes in three distinct shapes: a classic round table and two sizes of ovals.

Table top: Solid wood (oak or black coloured oak).
Base: Black powder coated steel.



Model: FH21
Height: 37 cm / 14.6 in
Length: 76 cm / 29.9 in
Width: 47 cm / 18.5 in



Model: FH41
Height: 37 cm / 14.6 in
Diameter: 80 cm / 31.5 in



Model: FH61
Height: 37 cm / 14.6 in
Length: 130 cm / 51.2 in
Width: 50 cm / 19.7 in



COFFEE TABLES

PLANNER™ TABLE SERIES

Design: Paul McCobb, 1953

The Planner™ coffee tables are part of a relaunched Fritz Hansen collection by Paul McCobb, a legendary designer known for creating slender designs where form follows function. Featuring a structured marble surface and a powder-coated steel base, the coffee table is an illustration of raw, tactile simplicity.

Table top: Marble (cream or charcoal).

Base: Black powder coated steel.



Model: MC300
Height: 40 cm / 15.7 in
Diameter: 80 cm / 31.5 in



Model: MC330
Height: 40 cm / 15.7 in
Length: 45 cm / 17.72 in
Width: 45 cm / 17.72 in



Model: MC310
Height: 40 cm / 15.7 in
Length: 75 cm / 29.5 in
Width: 45 cm / 17.7 in



Model: MC340
Height: 40 cm / 15.7 in
Length: 100 cm / 39.37 in
Width: 100 cm / 39.37 in



Model: MC320
Height: 40 cm / 15.7 in
Length: 80 cm / 31.5 in
Width: 80 cm / 31.5 in



Model: MC350
Height: 40 cm / 15.7 in
Length: 130 cm / 51.18 in
Width: 70 cm / 27.56 in

COFFEE TABLES

AJ TROLLEY

Design: Arne Jacobsen, 1955

As a stainless steel bar cart, serving trolley or side table, this mobile design is versatile with a sophisticated, architectural edge. Arne Jacobsen originally designed this elegant trolley for his tea, and the design has remained 'modern' – and very useful.

Table top: Black coloured ash.
Base: Stainless steel hairline.



Model: 840410
Height: 54.7 cm / 21.5 in
Length: 67 cm / 26.5 in
Width: 59 cm / 23 in
Note: Accessories assortment

PK62™

Design: Poul Kjærholm, 1968

In 1968, Poul Kjærholm set out to design a series of tables that could be combined with his collection of lounge chairs and sofas. The resulting PK62™ was created in connection with the development of two other chairs: the PK20™ and PK24™. A design favourite, the statement side table features a satin-brushed stainless steel base and a tabletop made of slate, marble or granite.

Table top: Slate, marble or granite.
Base: Satin brushed stainless steel.



Model: PK62
Height: 17 cm / 6.7 in
Length: 80 cm / 31.5 in
Width: 27 cm / 10.6 in

PK63™

Design: Poul Kjærholm, 1968

In 1968, Poul Kjærholm set out to design a series of tables that could be combined with his collection of lounge chairs and sofas. The resulting PK63™ was created in connection with the PK31™ 2-seater and 3-seater sofas. The iconic coffee table features a satin-brushed stainless steel base and a tabletop made of slate, marble or granite.

Table top: Slate, marble or granite.
Base: Satin brushed stainless steel.



Model: PK63
Height: 31 cm / 12.2 in
Length: 180 cm / 70.9 in
Width: 60 cm / 23.6 in

PK63A™

Design: Poul Kjærholm, 1968

In 1968, Poul Kjærholm set out to design a series of tables that could be combined with his collection of lounge chairs and sofas. The resulting PK63A™ was created in connection with the PK31™ 2-seater and 3-seater sofas. The iconic coffee table features a satin-brushed stainless steel base and a tabletop made of slate, marble or granite.

Table top: Slate, marble or granite.
Base: Satin brushed stainless steel.



Model: PK63A
Height: 31 cm / 12.2 in
Length: 120 cm / 47.2 in
Width: 60 cm / 23.6 in

COFFEE TABLES

PK61™

Design: Poul Kjærholm, 1956

The PK61™ coffee table is as minimalistic as it gets from the hand of Poul Kjærholm. The square, aesthetic design serves as a powerful manifesto and shows Kjærholm's development from industrial designer to noteworthy furniture architect.

Table top: Slate, marble, granite or glass.
Base: Satin brushed stainless steel.



Model: PK61
Height: 32 cm / 12.6 in
Length: 80 cm / 31.5 in
Width: 80 cm / 31.5 in

PK61A™

Design: Poul Kjærholm, 1956

The PK61A™ is an enlarged version of Poul Kjærholm's PK61™ coffee table. Four base elements are joined with industrial screws to create a unique, distinguished look. The removable tabletop demonstrates Kjærholm's recurring principle of using gravity to keep the elements in place.

Table top: Marble, granite or glass.
Base: Satin brushed stainless steel.



Model: PK61A
Height: 32 cm / 12.6 in
Length: 120 cm / 47.2 in
Width: 120 cm / 47.2 in

PK65™

Design: Poul Kjærholm, 1979

This unique coffee table refers back to the best traditions of Scandinavian craftsmanship. As with several of his tables, Kjærholm created PK65™ to complement one or more of his many chairs and sofas; in this case, the PK20™ lounge chair.

Table top: Slate, marble, granite or glass.
Base: Satin brushed stainless steel.



Model: PK65
Height: 38 cm / 15 in
Length: 100 cm / 39.4 in
Width: 100 cm / 39.4 in

PK71™

Design: Poul Kjærholm, 1957

The PK71™ comprises of a series of three nesting tables, designed to be stored and stacked under each other. With their toy-like appearance, the small, abstract tables were designed to be shuffled around and used together or separate. Today, the PK71 are displayed in a permanent collection at the Museum of Modern Art in New York.

Table top: Acrylic (black or white).
Base: Satin brushed stainless steel.



Model: PK71
Height: 25.5, 27, 28.5 cm / 10, 10.6, 11.2 in
Length: 25, 26.5, 28 cm / 9.8, 10.4, 11 in
Width: 25, 26.5, 28 cm / 9.8, 10.4, 11 in

TABLES

TABLE SERIES™

Design: Piet Hein/Bruno Mathsson/Arne Jacobsen, 1968

Fritz Hansen offers a wide range of tables assembled from legendary design components. Elegant tables can be created to complement any interior design.

Table top: Laminate or veneer (walnut).

Base (column): Satin polished aluminium/chromed steel/ powder coated steel.

Base (span legs): Chromed or powder coated steel.



Model: B612 (Superellipse™)
Height: 72 cm / 28.3 in
Length: 150 cm / 59.1 in
Length between legs: 92 cm / 36.2 in
Width: 100 cm / 39.4 in
Features: Detachable legs

Available in additional 5 sizes.



Model: B620 (Superellipse™)
Height: 72 cm / 28.3 in
Length: 170-270 cm / 66.9-106 in
Width: 100 cm / 39.4 in
Features: Extendable, Detachable legs

Available in additional 1 size.



Model: A622 (Circular)
Height: 72 cm / 28.3 in
Diameter: 75 cm / 29.5 in

Available in additional 1 size.



Model: A626 (Circular)
Height: 72 cm / 28.3 in
Diameter: 145 cm / 57.1 in

Available in additional 1 size.



Model: A602 (Supercircular™)
Height: 72 cm / 28.3 in
Length: 75 cm / 29.5 in
Width: 75 cm / 29.5 in

Available in additional 1 size.



Model: B637 (Rectangular)
Height: 72 cm / 28.3 in
Length: 140 cm / 55.1 in
Length between legs: 112 cm / 44.1 in
Width: 80 cm / 31.5 in
Features: Detachable legs

Available in additional 1 size.

Available in additional height

TABLES

FH125

Design: Piet Hein/Bruno Mathsson, 2019

The FH125 is a small, sophisticated dining table. Its rounded rectangular shape seats 4-6 and features a modern, white laminate top and elegant, aluminium edge.

Table top: Laminate (white).
Base: Chromed steel.



Model: FH125
Height: 72 cm / 28.3 in
Length: 125 cm / 49.2 in
Length between legs: 87 cm / 34.3 in
Width: 90 cm / 35.4 in
Features: Detachable legs



ANALOG™

Design: Jaime Hayon, 2014

Analog™ is not a square, not a circle, not an oval. Instead, designer Jaime Hayon fuses the best of all three classic shapes to create an entirely new and organic form. The result is a beautiful, wood-based platform for sharing meals and conversations.

Table top: Laminate (white) or veneer (oak or walnut).
Base: Solid wood (black lacquered oak, oak or walnut).



Model: JH43
Height: 72 cm / 28.3 in
Length: 130 cm / 51.2 in
Length between legs: 66 cm / 26 in
Width: 105 cm / 41.3 in



Model: JH63
Height: 72 cm / 28.3 in
Length: 185 cm / 72.8 in
Length between legs: 117 cm / 46.1 in
Width: 105 cm / 41.3 in



Model: JH83
Height: 72 cm / 28.3 in
Length: 245 cm / 96.5 in
Length between legs: 177 cm / 69.7 in
Width: 105 cm / 41.3 in

TABLES

ESSAY™

Design: Cecilie Manz, 2009

Essay™ is an exclusive table series in solid wood, created by Danish designer Cecilie Manz. The table consists of three elements - a tabletop and two bases - crafted in a simple, natural form. With its elegant look and flexible functionality, the table serves as the ideal gathering point in contemporary spaces.

Table top: White pigmented oak (solid wood)/ Oak (solid wood).

Base: White pigmented oak (solid wood)/ Oak (solid wood).

Extension leaf: Black laminate

(Length 48 cm/18.9 in, Width: 100 cm/39.4 in).



Model: CM12
Height: 72 cm / 28.3 in
Length: 190 cm / 74.8 in
Length between legs: 123 cm / 48.4 in
Width: 100 cm / 39.4 in
Features: Extendable



Model: CM22
Height: 72 cm / 28.3 in
Length: 230 cm / 90.5 in
Length between legs: 112 cm / 44.1 in
Width: 100 cm / 39.4 in
Features: Extendable



Model: CM32
Height: 72 cm / 28.3 in
Length: 265 cm / 104.3 in
Length between legs: 128 cm / 50.4 in
Width: 100 cm / 39.4 in
Features: Extendable



Model: CM42
Height: 72 cm / 28.3 in
Length: 295 cm / 116 in
Length between legs: 176 cm / 69.3 in
Width: 100 cm / 39.4 in
Features: Extendable

TABLES

PK54™

Design: Poul Kjærholm, 1963

The PK54™ dining table represents an exploration of contrasting materials and forms by Poul Kjærholm. Circle meets square, marble meets mineral – every time you look at it, new details emerge. Featuring Italian marble or granite and a satin-polished steel frame, the table's delicate unevenness makes it the natural focal point in any room.

Table top: Marble or granite.
Base: Satin brushed stainless steel.



Model: PK54
Height: 69 cm / 27.2 in
Diameter: 140 cm / 55.1 in
Features: Extendable (w. PK54A™)

PK54A™

Design: Poul Kjærholm, 1963

The PK54A™ extension ring provides a unique solution for those looking to extend the original PK54™ round dining table. Stone meets wood, hard meets soft – the table completely transforms appearance when the wooden extension ring is added. Perfect for plates around the table and a beautiful addition to the design.

Expansion ring: Solid wood (maple).
Storage unit: Solid wood (maple).



Model: PK54 + PK54A
Height: 70 cm / 27.6 in
Diameter: 210 cm / 82.7 in
Features: Storage unit

PK58™

Design: Poul Kjærholm, 1963/2007

PK58™ is a minimalist table inspired by PK54™ although the table is slightly taller with different materials. The proportions are still carefully considered and beautifully executed, with a blend of circular tabletop and a cube base with sharp angles.

Table top: Polyester composite (white).
Base: Anodised satin brushed aluminium.



Model: PK58
Height: 71 cm / 28 in
Diameter: 130 cm / 51.2 in

PK40™

Design: Poul Kjærholm, 1980

PK40™ is a unique version of Poul Kjærholm's square conference table with a leather-covered tabletop and a stainless steel base. The juxtaposition of materials is remarkable, a truly luxury design executed with full attention to detail.

Table top: Leather.
Base: Satin brushed stainless steel.



Model: PK40
Height: 70 cm / 27.6 in
Length: 140 cm / 55.1 in
Width: 140 cm / 55.1 in

TABLES

PLURALIS™

Design: Kasper Salto, 2016

As inferred by its name, the Pluralis™ table by Kasper Salto offers a myriad of possibilities. Characterised by its understated design, elegance and uncompromising quality, it brings a whole new level of functionality to the workspace.

Table top: Wood, Laminate, Linoleum.
Base: Polished or powder coated aluminium.

Accessories: Cable management etc.
Features: Overhang on one or two end(s), options of table widths.



Model: KS420
Height: 72 cm / 28.3 in
Length: 160 cm / 63.0 in
Length between legs: 146 cm / 57.5 in
Width: 80 cm / 31.5 in



Model: KS421
Height: 72 cm / 28.3 in
Length: 200 cm / 78.7 in
Length between legs: 188 cm / 74.0 in
Width: 80 cm, 90 cm or 100 cm / 31.5 in, 35.4 in or 39.4 in



Model: KS422
Height: 72 cm / 28.3 in
Length: 240 cm / 94.5 in
Length between legs: 228 cm / 89.8 in
Width: 80 cm, 90 cm, 100 cm or 120 cm / 31.5 in, 35.4 in, 39.4 in or 47.2 in



Model: KS423
Height: 72 cm / 28.3 in
Length: 320 cm / 126.0 in
Length between legs: 150 cm / 59.3 in
Width: 90 cm, 100 cm or 120 cm / 35.4 in, 39.4 in or 47.2 in



TABLES

PK51™

Design: Poul Kjærholm, 1957

The PK51™ is an iconic rectangular worktable handcrafted in 1957 by Poul Kjærholm. Characterised by an ash veneer tabletop and a satin-brushed stainless steel frame, the table was originally launched together with PK11™ as a matching set.

Table top: Ash veneer.
Base: Satin brushed stainless steel.



Model: PK51
Height: 72 cm / 28.3 in
Length: 204 cm / 80.3 in
Width: 102 cm / 40.2 in

PK55™

Design: Poul Kjærholm, 1957

The PK55™ is an iconic rectangular worktable handcrafted in 1957 by Poul Kjærholm. Characterised by an ash veneer tabletop and a satin-brushed stainless steel frame, the PK55 was launched as a smaller version of the PK51™.

Table top: Ash veneer.
Base: Satin brushed stainless steel.



Model: PK55
Height: 72 cm / 28.3 in
Length: 180 cm / 70.9 in
Width: 90 cm / 35.4 in

BAR TABLE SERIES

Design: Piet Hein/Arne Jacobsen, 1968

Fritz Hansen offers a wide range of bar tables assembled from legendary design components, in keeping with the Table Series design DNA. Elegant bar tables can be created to complement any interior design.

Table top: Laminate or veneer (walnut).
Base: Satin polished aluminium/satin chromed steel/ powder coated steel.



Model: A902 (Super-Circular™)
Height: 108 cm / 42.5 in
Length: 75 cm / 29.5 in
Width: 75 cm / 29.5 in



Model: A922 (Circular)
Height: 108 cm / 42.5 in
Diameter: 75 cm / 29.5 in

SHELVING

PLANNER™ SHELVING

Design: Paul McCobb, 1952

Designed by the late Paul McCobb, a pioneer of contemporary democratic design, the Planner™ Shelving series combines his signature graphic aesthetic with elegant expression. Named after its ability to help shape the design of a room, the simple yet striking shelving is available in three versions, each in varying heights and configurations.

Shelves: Oak veneer.

Base: Black powder coated steel.



Model: MC500
Height: 84.4 cm / 33.2 in
Width: 120.7 cm / 47.5 in
Depth: 38.1 cm / 15 in



Model: MC510
Height: 123.2 cm / 48.5 in
Width: 120.7 cm / 47.5 in
Depth: 38.1 cm / 15 in



Model: MC520
Height: 165 cm / 65 in
Width: 120.7 cm / 47.5 in
Depth: 38.1 cm / 15 in



ACCESSORIES

RUGS

Design: Cecilie Manz, 2020

Handmade rugs add colour and sophisticated dimension at floor level. Various tufting heights within each design make them subtly three-dimensional and tactically interesting.

Material: 100% wool, handtufted.



Name: Balance
Model: 840401
Length: 130 cm / 51.1 in
Width: 103 cm / 40.5 in

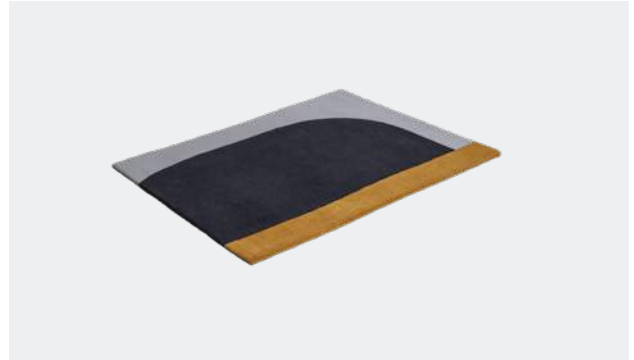

Name: Ochre
Model: 840403
Length: 130 cm / 51.1 in
Width: 103 cm / 40.5 in



Name: Dotted Balance
Model: 840402
Length: 130 cm / 51.1 in
Width: 103 cm / 40.5 in



Name: Dots
Model: 840400
Length: 190 cm / 75 in
Width: 150 cm / 59 in

LIGHTING

AEON ROCKET™

Design: Morten Voss, 2012



Category: Pendant
Model: P1
Height: 23.6 cm / 9.2 in
Diameter: 40 cm / 15.7 in
Colour: Aeon-Grey, Aeon-Black



Category: Pendant
Model: P3
Height: 33.2 cm / 12.9 in
Diameter: 60 cm / 23.6 in
Colour: Aeon-Grey, Aeon-Black



AQ01™

Design: Anne Qvist, 2017



Category: Table lamp
Height: 44 cm / 17.3 in
Width: 45 cm / 17.7 in
Colour: White, Black, Blue
Features: Tilttable, Swivel, Dimmable



Category: Table lamp (Plug-in)
Height: 45.3 cm / 17.8 in
Width: 45 cm / 17.7 in
Colour: White, Black, Blue
Features: Tilttable, Swivel, Dimmable

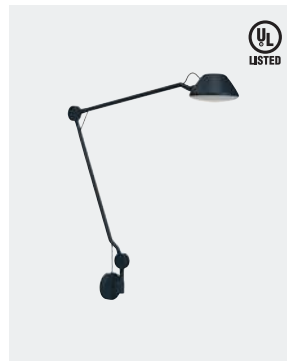

Category: Wall lamp
Height: 48.3 cm / 17.8 in
Width: 45 cm / 17.7 in
Colour: White, Black, Blue
Features: Tilttable, Swivel, Dimmable

AVION™

Design: Iskos-Berlin, 2012



Category: Pendant
Height: 34.2 cm / 13.5 in
Width: 85 cm / 33.5 in
Colour: White

CALABASH™

Design: Komplot Design, 2010



Category: Pendant
 Model: P1
 Height: 21 cm / 8.3 in
 Diameter: 15.8 cm / 6.2 in
 Colour: Gold, Silver, Grey Meteor, Black Meteor



Category: Pendant
 Model: P2
 Height: 30.5 cm / 12 in
 Diameter: 22.4 cm / 8.8 in
 Colour: Gold, Silver, Grey Meteor, Black Meteor

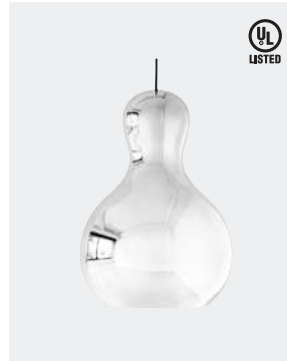

Category: Pendant
 Model: P3
 Height: 48.4 cm / 19 in
 Diameter: 34 cm / 13.4 in
 Colour: Silver

CARAVAGGIO™

Design: Cecilie Manz, 2005



Category: Pendant
 Model: PO LED
 Height: 14.5 cm / 5.7 in
 Diameter: 11 cm / 4.3 in
 Colour: Opal



Category: Pendant
 Model: P1
 Height: 21.6 cm / 8.5 in
 Diameter: 16.5 cm / 6.4 in
 Colour: White, Black, BlackBlack, White (matt), Grey25, Grey45, Black (matt), Opal



Category: Pendant
 Model: P2
 Height: 33.7 cm / 13.2 in
 Diameter: 25.8 cm / 10.1 in
 Colour: White, Black, BlackBlack, White (matt), Grey25, Grey45, Black (matt), Opal



Category: Pendant
 Model: P3
 Height: 51.6 cm / 20.3 in
 Diameter: 40 cm / 15.7 in
 Colour: White, Black, BlackBlack, White (matt), Grey25, Grey45, Black (matt), Opal

CONCERT™

Design: Jørn Utzon, 2005



Category: Pendant
 Model: P1
 Height: 16.6 cm / 6.4 in
 Diameter: 32 cm / 12.5 in
 Colour: White



Category: Pendant
 Model: P3
 Height: 32 cm / 12.5 in
 Diameter: 55 cm / 21.6 in
 Colour: White

CLAM™

Design: Ahm & Lund



Category: Pendant
 Model: Ø440
 Height: 52.2 cm / 20.5 in
 Diameter: 44 cm / 17.3 in
 Colour: Opal glass/ brass



Category: Pendant
 Model: Ø550
 Height: 54 cm / 21.3 in
 Diameter: 55 cm / 21.7 in
 Colour: Opal glass/ brass

CARAVAGGIO™ READ

Design: Cecilie Manz, 2005



Category: Wall lamp
Height: 20.6 cm / 8.1 in
Width: 35 cm / 13.7 in
Colour: White, Grey25, Black, Opal
Features: Tilttable, Swivel

ORIENT™

Design: Jo Hammerborg, 1963

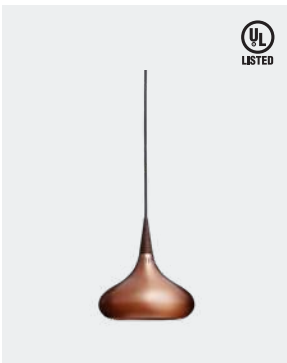

Category: Pendant
Model: P1
Height: 24.5 cm / 9.6 in
Diameter: 22.5 cm / 8.8 in
Material/Colour: Aluminium/Oak,
Black/Rosewood, Copper/Rosewood



Category: Pendant
Model: P2
Height: 37 cm / 14.5 in
Diameter: 34 cm / 13.3 in
Material/Colour: Aluminium/Oak,
Black/Rosewood, Copper/Rosewood

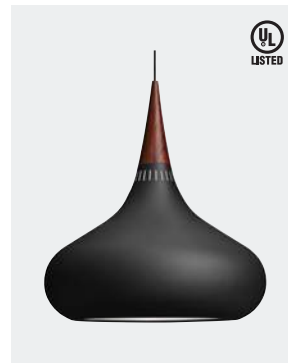

Category: Pendant
Model: P3
Height: 54 cm / 21.2 in
Diameter: 50 cm / 19.6 in
Material/Colour: Aluminium/Oak,
Black/Rosewood

CROSS-PLEX™

Design: Bodil Kjær, 1961



Category: Table lamp
Model: T-300
Height: 30 cm / 11.8 in
Width: 40 cm / 15.8 in
Colour: Opal/Clear



Category: Table lamp
Model: T-500
Height: 50 cm / 19.7 in
Width: 20 cm / 7.9 in
Colour: Opal/Clear

DOGU™

Design: Michael Geertsen, 2016



Category: Pendant
Height: 32.9 cm / 13 in
Diameter: 24 cm / 9.5 in
Material/Colour: Bone china/Gold,
Bone china/Silver

KAISER idell™

Design: Christian Dell, 1931



Category: Pendant
Model: 6722-P
Height: 15.5 cm / 6.1 in
Diameter: 14.5 cm / 5.7 in
Colour: Black, Russet red, Soft ochre, Smooth slate

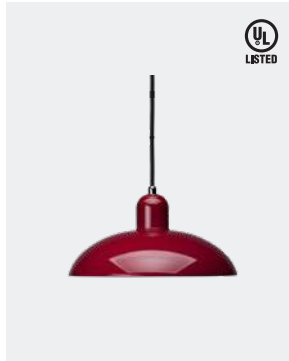

Category: Pendant
Model: 6631-P
Height: 13.5 cm / 5.3 in
Diameter: 28.5 cm / 11.2 in
Colour: White, Black, Matt black, Ruby red

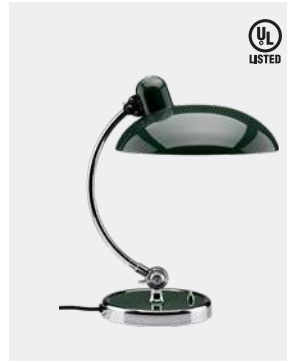

Category: Table lamp
Model: 6631-T Luxus
Height: 42.5 cm / 16.7 in
Diameter (shade): 28.5 cm / 11.2 in
Diameter (base): 19.4 cm / 7.6 in
Colour: White, Black, Matt black*, Ruby red, Dark green, Easy Grey*
Features: Tilttable
* Available with Brass or standard Chrome elements



Category: Table lamp
Model: 6556-T
Height: 47 cm / 18.5 in
Diameter (shade): 21.5 cm / 8.5 in
Diameter (base): 18.5 cm / 7.3 in
Colour: White, Black, Matt Black, Easy Grey*
Features: Tilttable
* Available with Brass elements



Category: Floor lamp
Model: 6580-F Luxus
Height: 125-135 cm / 49.2-53.1 in
Diameter (shade): 21.5 cm / 8.5 in
Diameter (base): 22.5 cm / 8.9 in
Colour: White, Black, Matt black
Features: Height adjustable, Swivel



Category: Floor lamp
Model: 6556-F
Height: 125 cm / 49.2 in
Diameter (shade): 21.5 cm / 8.5 in
Diameter (base): 22.5 cm / 8.9 in
Colour: White, Black, Matt black, Easy Grey*
Features: Tilttable
* Available with Brass elements

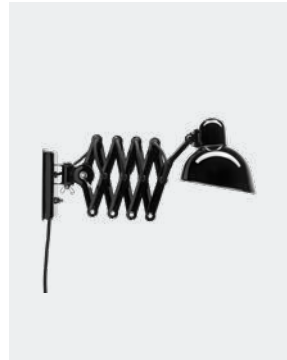

Category: Wall lamp
Model: 6718-W
Height (base): 14.8 cm / 5.8 in
Diameter (shade): 16.4 cm / 6.5 in
Width: 47-89 cm / 18.5-35 in
Colour: White, Black, Matt black
Features: Stretchable, Swivel

MALUMA™

Design: Fumie Shibata, 2021



Category: Pendant
Model: H350
Height: 35 cm / 13.8 in
Diameter: 23.5 cm / 9.3 in
Colour: Rose, Plum, Moss

NIGHT OWL™

Design: Nikolai Wiig Hansen, 2015

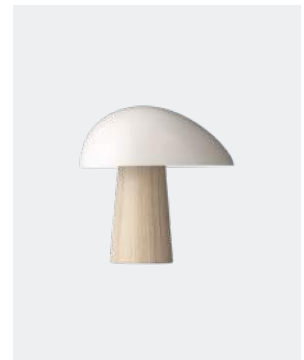

Category: Table lamp
Height: 23.9 cm / 9.4 in
Diameter: 23.5 cm / 9.2 in
Colour: Midnight blue, Smokey white, Midnight blue/Ash, Smokey white/Ash

LIGHTING

SILHUET

Design: Jo Hammerborg, 1977



Category: Pendant
Model: P2
Height: 32.8 cm / 12.9 in
Diameter: 29.5 cm / 11.6 in
Colour: Brushed brass, Polished brass

SUSPENCE™

Design: GamFratesi, 2013



Category: Pendant
Model: P1
Height: 22.5 cm / 8.8 in
Diameter: 24 cm / 9.4 in
Colour: White, Light grey, Black, Copper

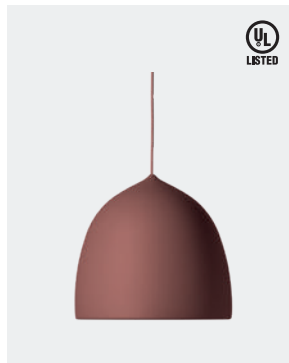

Category: Pendant
Model: P1.5
Height: 29.8 cm / 11.7 in
Diameter: 32 cm / 12.6 in
Colour: Light grey, Powder burgundy, Pale yellow

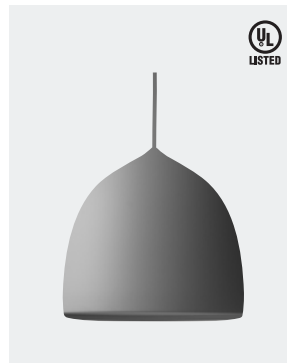

Category: Pendant
Model: P2
Height: 36 cm / 14.2 in
Diameter: 38.5 cm / 15.1 in
Colour: White, Light grey, Black, Copper

PM-02

Design: Paul McCobb, 1950



Category: Table lamp
Height: 31.4 cm / 12.3 in
Diameter: 13.6 cm / 5.3 in
Colour: Opal/Black, Opal/Brass



VASES



Model: Ikebana Vase
Designer: Jaime Hayon
Height: 15.5 cm / 6.1 in
Diameter: 24 cm / 9.4 in
Material: Glass/Brass

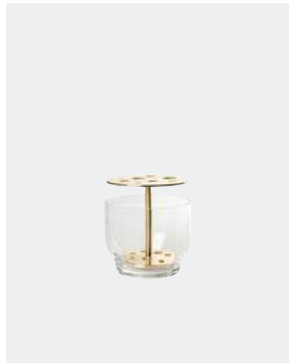

Model: Ikebana Vase Small
Designer: Jaime Hayon
Height: 13 cm / 5.1 in
Diameter: 12 cm / 4.7 in
Material: Glass/Brass



Model: Ikebana Vase Long
Designer: Jaime Hayon
Height: 13 cm / 5.1 in
Length: 33.5 cm / 13.2 in
Width: 9.5 cm / 3.7 in
Material: Glass/Brass



Model: Moon Eye Vase
Designer: Grethe Meyer
Height: 23 cm/9.1 in, 16 cm/6.3 in
Width: 16 cm/6.3 in, 13.5 cm/5.3 in
Depth: 8 cm/3.1 in, 8 cm/3.1 in
Colour: Clear and Smoked/Clear glass



Model: Ikeru Vase High
Designer: Jaime Hayon
Height: 23.9 cm / 9.4 in
Diameter: 16 cm / 6.3 in
Material: Forest green glass/Aluminium



Model: Ikeru Vase Low
Designer: Jaime Hayon
Height: 13.1 cm / 5.1 in
Diameter: 19 cm / 7.4 in
Material: Forest green glass/Aluminium



ACCESSORIES

CANDLEHOLDERS



Model: Louise Candleholder
Designer: Grethe Meyer
Height: 2.1 cm / 0.8 in
Diameter: 6.9 cm / 2.7 in
Material: Silver plated stainless steel

CANDLEHOLDERS



Model: Candleholder Single #1
Designer: Jaime Hayon
Height: 10.5 cm / 4.1 in
Diameter: 5 cm / 2 in
Colours: Brass



Model: Candleholder Single #2
Designer: Jaime Hayon
Height: 13 cm / 5.1 in
Diameter: 4 cm / 1.6 in
Colours: Brass

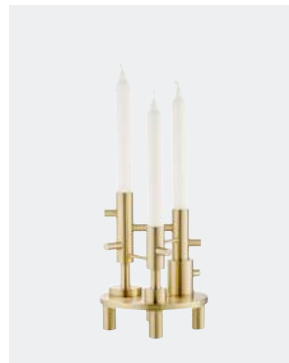

Model: Candleholder Large
Designer: Jaime Hayon
Height: 20 cm / 7.9 in
Diameter: 16 cm / 6.3 in
Material: Brass



Model: Candleholder Single #1
Designer: Jaime Hayon
Height: 10.5 cm / 4.1 in
Diameter: 5 cm / 2 in
Colours: Stainless steel



Model: Candleholder Single #2
Designer: Jaime Hayon
Height: 13 cm / 5.1 in
Diameter: 4 cm / 1.6 in
Colours: Stainless steel



Model: Candleholder Large
Designer: Jaime Hayon
Height: 20 cm / 7.9 in
Diameter: 16 cm / 6.3 in
Material: Stainless steel

CUSHIONS



Model: Cushion Vertigo
Designer: Arne Jacobsen
Height: 50 cm / 19.7 in
Width: 50 cm / 19.7 in
Colour: Light grey



Model: Cushion Vertigo
Designer: Arne Jacobsen
Height: 40 cm / 15.7 in
Width: 60 cm / 23.6 in
Colour: Light grey



Model: Cushion Trapez
Designer: Arne Jacobsen
Height: 50 cm / 19.7 in
Width: 50 cm / 19.7 in
Colours: Midnight blue



Model: Cushion Trapez
Designer: Arne Jacobsen
Height: 40 cm / 15.7 in
Width: 60 cm / 23.6 in
Colours: Midnight blue



Model: Cushion Tassel
Designer: Arne Jacobsen
Height: 45 cm / 17.7 in
Width: 45 cm / 17.7 in
Colour: Ochre yellow



Model: Cushion Tassel
Designer: Arne Jacobsen
Height: 36 cm / 14.1 in
Width: 56 cm / 22 in
Colour: Ochre yellow



Model: Cushion
Designer: Alayu
Height: 40 cm / 15.7 in
Width: 60 cm / 23.6 in
Colours: Anthracite, Oat

THROWS



Model: Throw
Designer: Jaime Hayon
Length: 200 cm / 78.7 in
Width: 130 cm / 51.2 in
Colour: Gold



Model: Throw Cashmere
Designer: Fritz Hansen
Length: 190 cm / 74.8 in
Width: 120 cm / 47.2 in
Colour: Natural brown



Model: Classic Throw
Designer: Fritz Hansen
Length: 180 cm / 70.9 in
Width: 130 cm / 51.2 in
Colour: Grey

ACCESSORIES

COAT RACKS



Model: Coat Tree™ Wall
Designer: Sidse Werner
Height: 104 cm / 40.9 in
Width: 46 cm / 18.1 in
Depth: 30 cm / 11.8 in
Colours: Light grey, Dark blue



Model: Coat Tree™
Designer: Sidse Werner
Height: 193 cm / 76 in
Diameter: 65 cm / 25.6 in
Colour: Chrome
Note: Furniture assortment

HAPPY HOOK



Model: Happy Hook
Designer: Jaime Hayon
Height: 13 cm / 5.1 in
Width: 15 cm / 5.9 in
Depth: 6.5 cm / 2.5 in
Colours: Green grey, Blush, Dark turquoise

SLIDE



Model: Slide
Designer: Karin Nakamura
Height: 29.8 cm / 11.7 in
Length: 44 cm / 17.3 in
Depth: 14.3 cm / 5.6 in
Material: Smoked glass/Hand-cast concrete/Cork/Ash wood

BOXES



Model: Leather Box Small
Designer: August Sandgren
Height: 6.5 cm / 2.5 in
Length: 26 cm / 10.2 in
Width: 20.5 cm / 8 in
Material: Pure leather/Linen

DESK



Model: Wave
Designer: Hiromichi Konno
Height: 12 cm / 4.7 in
Width: 18 cm / 7.1 in
Depth: 16 cm / 6.3 in
Material: Soft coated steel/Leather
Colour: Black

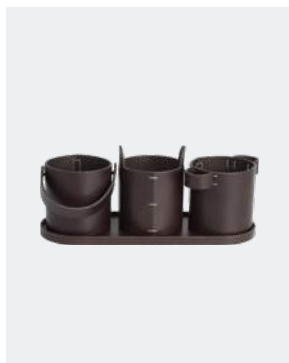

Model: Buckets
Designer: Mia Lagerman
Height: 12 cm / 4.7 in
Width: 30 cm / 11.8 in
Depth: 10.5 cm / 4.1 in
Material: Harness leather
Colour: Brown



Model: Desk Pad
Designer: Hiromichi Konno
Width: 55 cm / 21.7 in
Depth: 40 cm / 15.7 in
Material: Royal Nubuck leather
Colour: Lava grey

ACCESSORIES

MAGAZINE HOLDER



Model: Magazine Holder
Designer: Paul McCobb
Height: 45 cm / 17.7 in
Width: 33 cm / 13 in
Depth: 33 cm / 13 in
Material: Black powder coated steel/
Black-white textile

POUFS



Model: Pouf Large
Designer: Cecilie Manz
Height: 29 cm / 11.4 in
Diameter: 60 cm / 23.6 in
Colours: Concrete, Indigo, Beige



Model: Pouf Small
Designer: Cecilie Manz
Height: 24 cm / 9.5 in
Diameter: 50 cm / 19.7 in
Colours: Slate, Ultramarine,
Light Grey Leather

MIRRORS



Model: Table Mirror
Designer: Paul McCobb
Height: 51 cm / 20.1 in
Width: 32 cm / 12.6 in
Depth: 25 cm / 9.8 in
Materials: Black powder coated steel/
White Carrara marble



Model: Wall Mirror
Designer: Paul McCobb
Height: 157 cm / 61.8 in
Width: 39-75 cm / 15.3-29.5 in
Depth: 22 cm / 8.7 in
Materials: Black powder coated steel/
White Carrara marble

MINIATURES

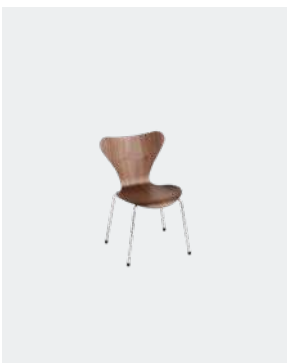

Model: Miniature Series 7™
Designer: Arne Jacobsen
Height: 13 cm / 5.1 in
Width: 8.5 cm / 3.3 in
Colours: Black, Opium red, Walnut



Model: Miniature Egg™
Designer: Arne Jacobsen
Height: 16.5 cm / 6.4 in
Width: 13.5 cm / 5.3 in
Colours: Black, Red

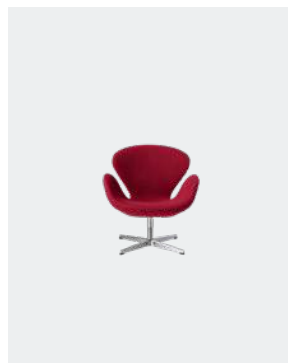

Model: Miniature Swan™
Designer: Arne Jacobsen
Height: 9 cm / 3.5 in
Width: 13.5 cm / 5.3 in
Colours: Black, Red

ACCESSORIES

SIDE TABLES



Model: Tray Table
Designer: Fritz Hansen
Height: 42 cm / 16.5 in
Diameter: 45 cm / 17.7 in
Materials: Oak, Black lacquered oak



Model: Tray Table Large
Designer: Fritz Hansen
Height: 39 cm / 16.5 in
Diameter: 60 cm / 17.7 in
Materials: Black lacquered oak



Model: AJ Trolley
Designer: Arne Jacobsen
Height: 54.7 cm / 21.5 in
Width: 67 cm / 26.5 in
Depth: 59 cm / 23 in
Material: Black coloured ash/
Stainless steel

STOOLS



Model: Dot™
Designer: Arne Jacobsen
Height: 46 cm / 18.1 in
Width: 34 cm / 13.4 in
Depth: 34 cm / 13.4 in
Colours: Black/Powder coated black,
Walnut/Chrome, Lava grey/Chrome



Model: High Dot™
Designer: Arne Jacobsen
Height: 65 cm / 25.6 in
Width: 44 cm / 17.3 in
Depth: 44 cm / 17.3 in
Colours: Black/Powder coated black,
Walnut/Chrome, Lava grey/Chrome

BASKET



Model: Basket
Designer: Benjamin Hubert
Height: 36.5 cm / 14.4 in
Length: 53 cm / 20.8 in
Width: 37 cm / 14.6 in
Material: Ash veneer

CHILDREN'S CHAIRS



Model: Series 7™ Children's Chair
Designer: Arne Jacobsen
Height: 60 cm / 23.6 in
Seat height: 34 cm / 13.3 in
Width: 40 cm / 15.7 in
Depth: 42 cm / 16.5 in
Colours: Black, Lavender Blue, Rose



Model: Series 7™ Junior
Designer: Arne Jacobsen
Height: 79 cm / 31.1 in
Seat height: 52 cm / 20.4 in
Width: 42 cm / 16.5 in
Depth: 44 cm / 17.3 in
Colour: Black, Oak

HEADQUARTERS

FRITZ HANSEN A/S
Allerødvej 8
3450 Allerød
Denmark
Tel: +45 48 17 23 00

GET IN TOUCH

SALES - ASIA & OCEANIA
customerserviceasia@fritzhanzen.com
Tel: +81 3 3400 3316

SALES - EUROPE
salesupport@fritzhanzen.com
Tel: +45 70 80 70 90

SALES - NORTH AMERICA
info@fritzhanzen.com
Tel: +001 212 219 3226

PRESS - GLOBAL
press@fritzhanzen.com
Tel: +45 25 19 07 03

LEARN MORE

NEWSLETTER
Sign up at:
fritzhanzen.com/newsletter

DOWNLOADS
Find 2D & 3D files, imagery,
product facts and much more at:
downloads.fritzhanzen.com

INSTAGRAM
[@fritzhanzen](https://www.instagram.com/fritzhanzen)

PINTEREST
Fritz Hansen™

FACEBOOK
Fritz Hansen

LINKEDIN
Fritz Hansen

THANKS TO

A_Design, vahle+nikolaisen,
Dansk form, Boho habits, Sunday-s
gallery, gallery pi, Fil de fer, Beau
march, Jacob grønbech, V1, Etage
projects, Emil Alenius Boserup,
studio X viaduct, Adorno, Anders
Scrmn Meisner/Hans Alf Gallery,
Anne Black, Atelier Plateau, Birgitte
Due Madsen, Cappelen Dimyr,
Durup, File Under Pop, Hein Studio,
Helle Mardahl, Helle Thygesen Art
& Antiques, Jesper Packness, Julie
Lænholm, Karakter Copenhagen,
Kusiner, Kvadrat, Les Gens Heureux,
Matias Moellenbach, Nina Nørgaard,
Nordic Modern, Paustian, Sacre
Coeur, Skagerak, Stelton, Tilde
Grynnerup, Tina Marie Cph, Yume

FRITZ HANSEN

HEADQUARTERS

FRITZ HANSEN A/S
Allerødvej 8
3450 Allerød
Denmark
Tel: +45 48 17 23 00

GET IN TOUCH

SALES - ASIA & OCEANIA
customerserviceasia@fritzhanzen.com
Tel: +81 3 3400 3316

SALES - EUROPE
salesupport@fritzhanzen.com
Tel: +45 70 80 70 90

SALES - NORTH AMERICA
info@fritzhanzen.com
Tel: +001 212 219 3226

PRESS - GLOBAL
press@fritzhanzen.com
Tel: +45 25 19 07 03

LEARN MORE

NEWSLETTER
Sign up at:
fritzhanzen.com/newsletter

DOWNLOADS
Find 2D & 3D files, imagery,
product facts and much more at:
downloads.fritzhanzen.com

INSTAGRAM
[@fritzhanzen](https://www.instagram.com/fritzhanzen)

PINTEREST
Fritz Hansen™

FACEBOOK
Fritz Hansen

LINKEDIN
Fritz Hansen

THANKS TO

A_Design, vahle+nikolaisen,
Dansk form, Boho habits, Sunday-s
gallery, gallery pi, Fil de fer, Beau
march, Jacob grønbech, V1, Etage
projects, Emil Alenius Boserup,
studio X viaduct, Adorno, Anders
Scrmn Meisner/Hans Alf Gallery,
Anne Black, Atelier Plateau, Birgitte
Due Madsen, Cappelen Dimyr,
Durup, File Under Pop, Hein Studio,
Helle Mardahl, Helle Thygesen Art
& Antiques, Jesper Packness, Julie
Lænholm, Karakter Copenhagen,
Kusiner, Kvadrat, Les Gens Heureux,
Matias Moellenbach, Nina Nørgaard,
Nordic Modern, Paustian, Sacre
Coeur, Skagerak, Stelton, Tilde
Grynnerup, Tina Marie Cph, Yume

FRITZ HANSEN